



# ***SlimLift*** **S.120**

*Multi-rail elevatório ou de correr em linha  
de vista perimetral ou minimalista  
com galandage, abertura de canto e fixo integrado  
Drenagem por rejingot e grelha de escoamento*

LOU / ALU

# S.120 - Desempenho / Performance



ITT - Ensaio de tipo inicial - Organismo notificado n.º

1668 - Ensatec

Norma EN 14351-1

ETI - Essai de type initial - Laboratoire notifié n.º



**Permeabilidade ao Ar**  
Perméabilité à l'air  
UNE-EN 12207

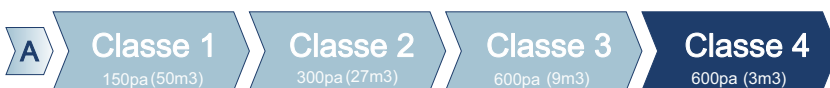

**Estanquicidade à Água**  
Étanchéité à l'eau  
UNE-EN 12208



**Resistência ao Vento**  
Résistance au Vent  
UNE-EN 12210

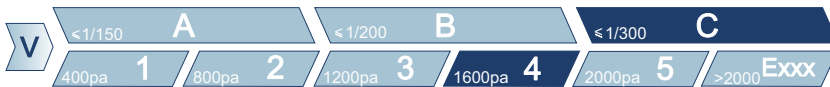

Ensaio realizado numa janela de Correr de duas folhas com: 3600 x 2200 mm (LxH) Certificado de ensaio/Certificat d'essai n.º 258070  
Essai réalisé sur une fenêtre coulissant à deux vantaux avec:

## Desempenho térmico e acústico / Performance thermique et acoustique

Elementos usados na base dos cálculos  
Elements utilisés sur la base de calculs:

$$U_w = \frac{\sum AgU_g + \sum AfU_f + \sum lg\psi_g}{\sum Ag + \sum Af}$$

Janela de correr de 2 folhas com:  
Fenêtre coulissant à 2 vantaux avec:  
5000 x 2500 mm (LxH)

Composição e valores dos vidros / Composition et valeurs de vitrage

	Unidade de vidro (IGU)*	Ψ	Ug	g	Tlg	Rw (C;Ctr)
(a)	Triplo 36 mm - 3.3' + 12kp + 4 + 10kp + 4'	0,044	0,4	0,38	60%	39(-2;-5)
(b)	Duplo 36 mm - 4.4' + 22 Ag + '6	0,049	1,0	0,25	43%	36(-2;-5)
(c)	Duplo 32 mm - 4.4' + 18 Ar + '6	0,049	1,3	0,25	43%	32(-1;-3)

Ψ - Coeficiente linear junta alumínio/vidro Ug - Coeficiente Térmico g - Factor Solar Tlg - Transmissão Luminosa



**Transmissão Térmica**  
Transmittance Thermique  
UNE-EN 10077-2

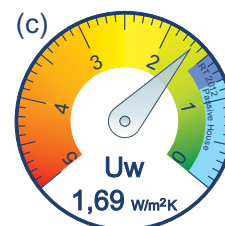
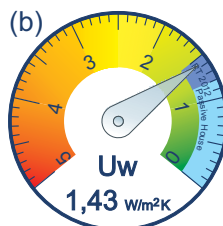
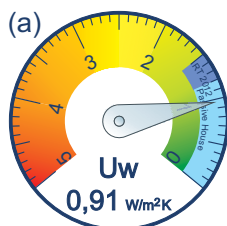
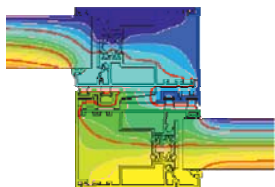

**Atenuação Acústica**  
Isolation Acoustique  
EN 14351-1+A1 (Anexo B)  
Rw (C;Ctr) com vidro / avec vitrage

- (a) 35 (-2;-3)
- (b) 32 (-2;-3)
- (c) 28 (-1;-2)

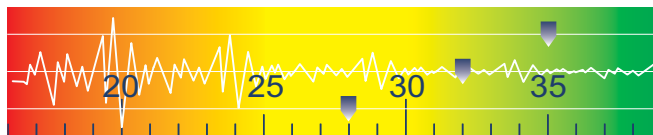

## Tipologia e Classe energética / Typologie et classe énergétique

Tipologia construtiva  
Typologie constructive  
Mono-rail, Bi-rail, Tri-rail... (n)-rail

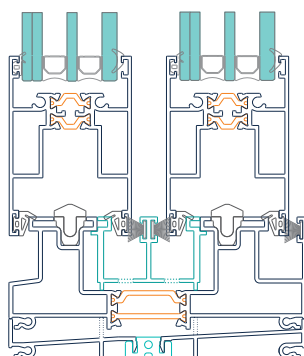
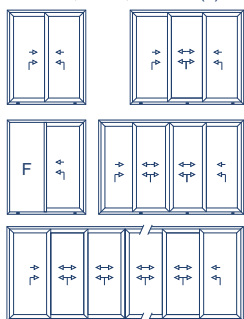

ETIQUETTE D'EFFICACITE ENERGETIQUE FENETRES & PORTES		Zones Climatiques France Métropolitaine		
		Z1	Z2	Z3
Bilan énergétique annuel	A			
	B			
Confort d'été	A			
	B			
Coefficient de transmission thermique: Uw= 1,2 W/m²K				
Facteur solaire: Sw= 0,40				
Transmission Luminieuse: Tlw= 61,7 %				
MENUISERIE Louvel - Systemes de AluMino				
MODELE S.120 Slim Lift - JCP2F 2350 x 2180 (LxH)				
Classification établi pour la France Métropolitaine suivant la méthode Etiquette-Energie-Menuiserie (E2M) disponible sur le site www.etiquette-energie-menuiserie.fr				

Avec vitrage (a)

Desempenho energético de:  
JCR2F - 5000 x 2500 - S.120

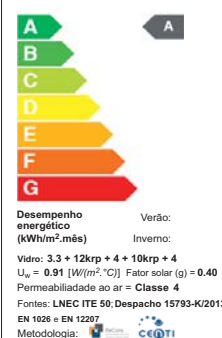

Desempenho energético (kWh/m².mês) Verão:  
Inverno:  
Vidro: 3.3 + 12krp + 4 + 10krp + 4  
Uw = 0.91 [W/m².K] Fator solar (g) = 0.40  
Permeabilidade ao ar = Classe 4  
Fontes: LNEC ITE 50, Despacho 15793-K/2013.  
EN 1028 e EN 12207  
Metodologia:

Com Vidro (a)

## Materiais, Tratamentos e Acabamentos / Matériaux, Traitement et Finition

Perfis / Profils: Liga / alliage EN AW - 6060 (T5) - Acessórios / Accessoires: do sistema  
Vedantes / Joint d'étanchéité: EPDM / mousse de EPDM - Poliamida / Polyamid: 16 e 30 mm  
Acabamentos / Finition: Anodizado, Lacado e efeito madeira / anodisé, Laqué et effet bois



\* Fonte: Guardian Performance Calculator 4.1 e Acoustic Database 20171102 by Guardian Glass. Os valores apresentados estão calculados para o vão descrito, com base nos valores dos vidros referenciados.

S.120



SlimLift

# S.120 - Slim Lift



Aros Fixos Multi-rail

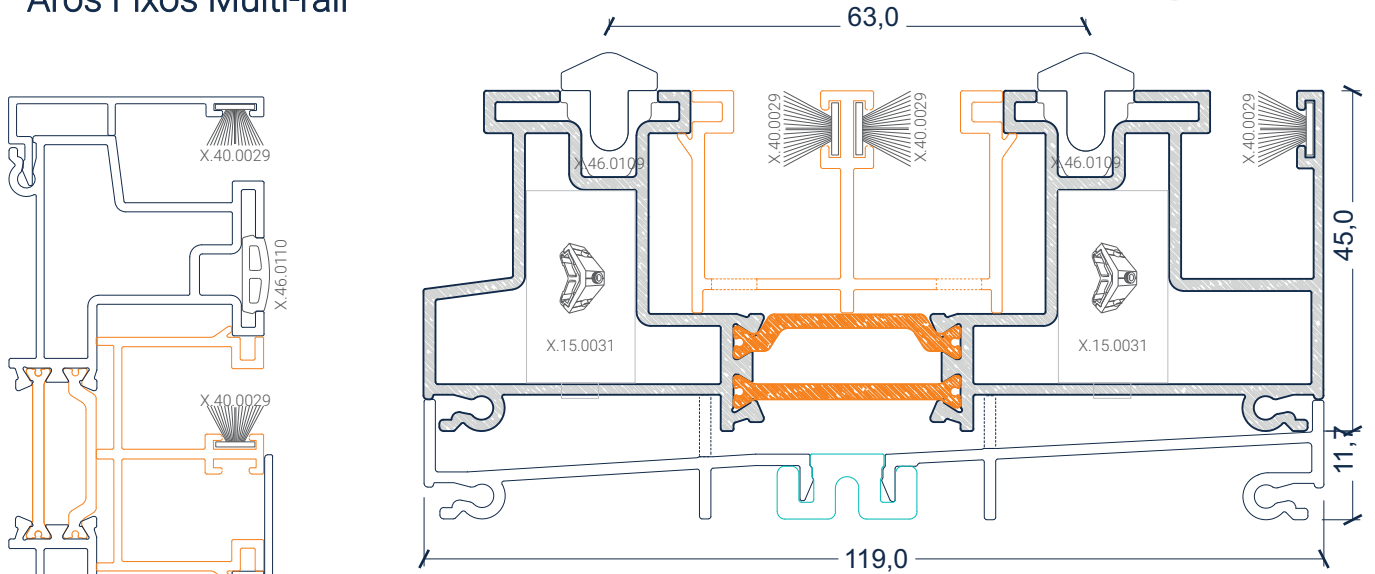

S.120.102



S.120.100

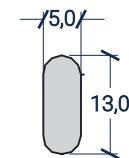

Y.0020

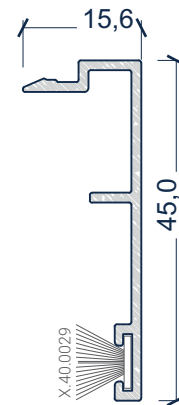

S.120.501

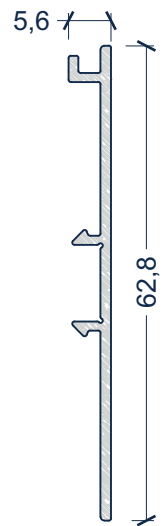

S.120.502



S.120.911  
(maquinado p/soleira)

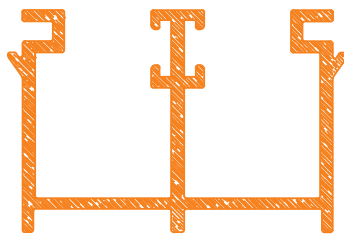

S.120.910  
(p/padieira e ombreiras)

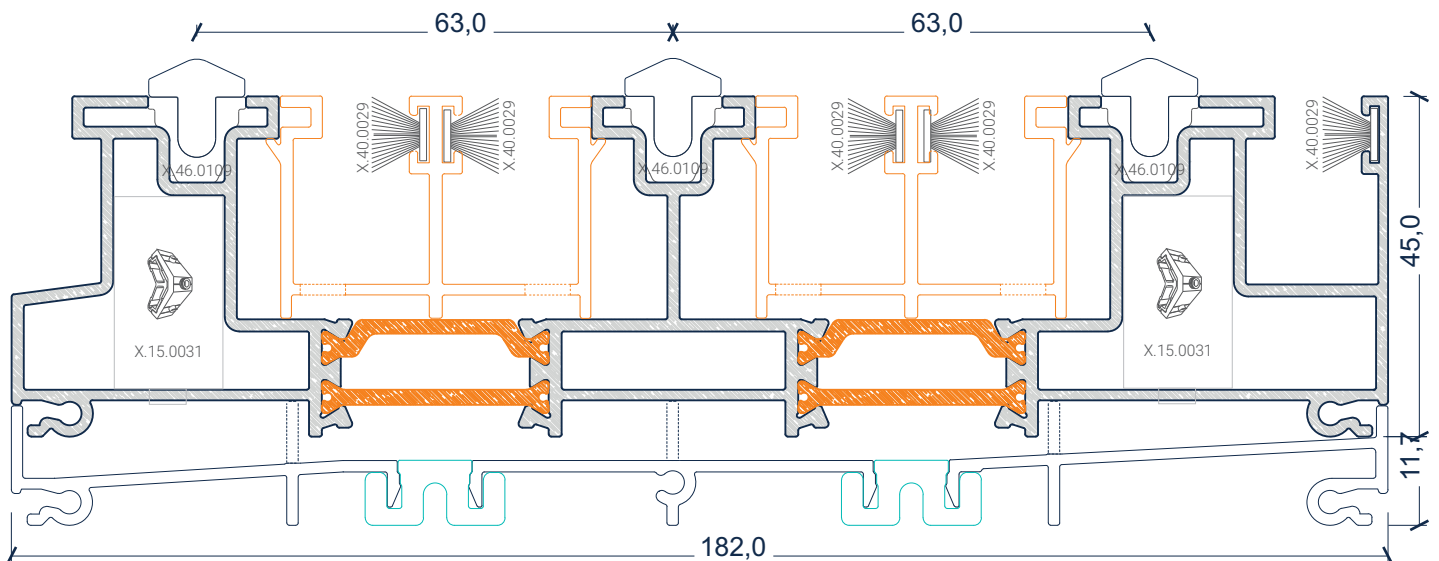

S.120.103



# S.120 - Slim Lift



## Rejingot e grelha de escoamento

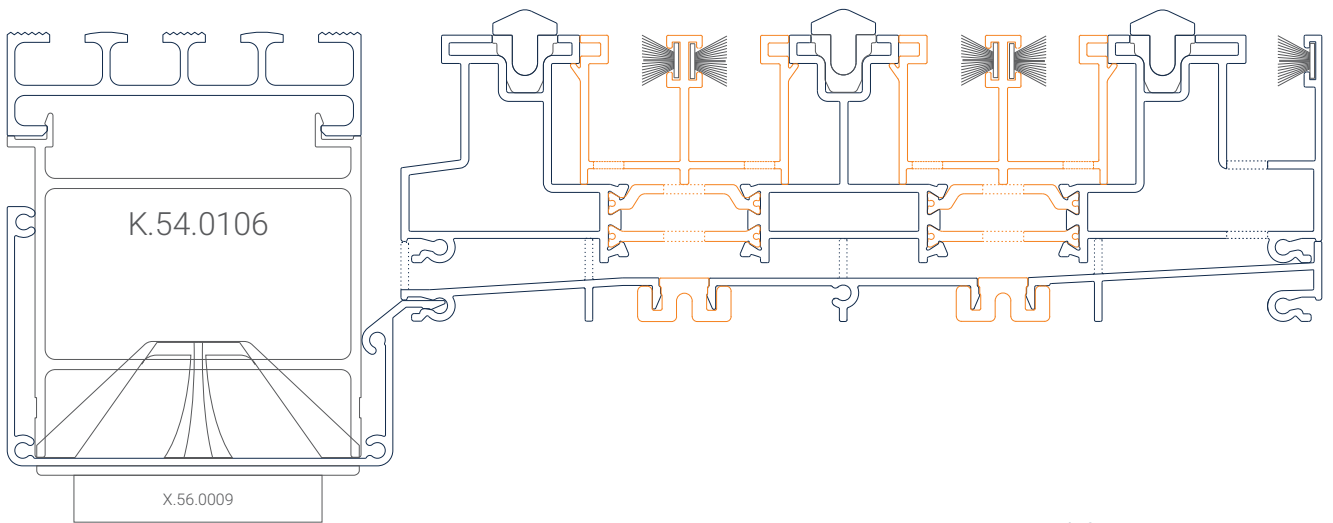

**S.120.930**

Poliamida união rejingots

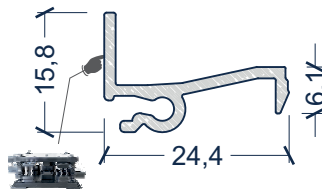

**S.120.435**

Rejingot exterior galandage

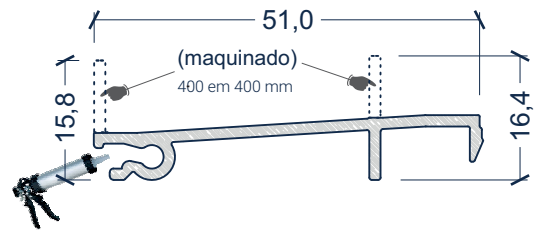

**S.120.430**

Rejingot exterior (a usar com escoador)

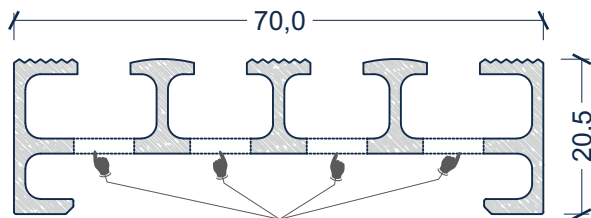

(maquinado)  
**Y.0302**

Grelha do escoador

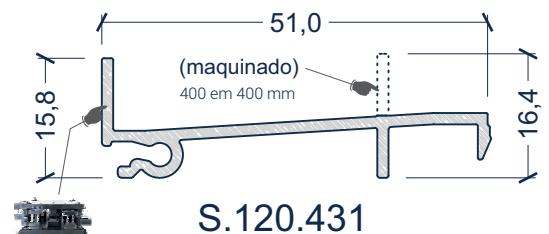

**S.120.431**

Rejingot exterior (a usar sem escoador)  
(cunhar para aplicar goteiras)

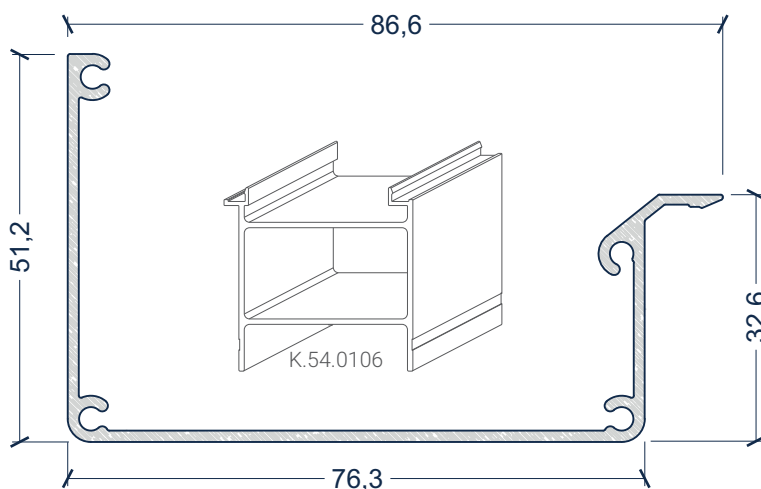

**Y.0301**

Canelão escoador

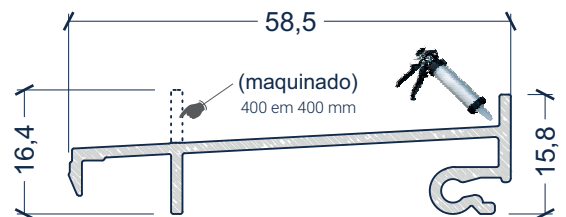

**S.120.432**

Rejingot interior

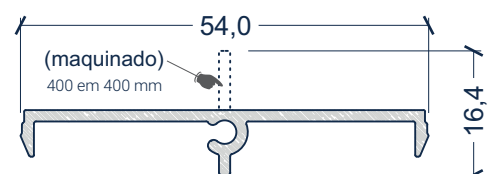

**S.120.433**

Rejingot central (multirail)



K.54.0106

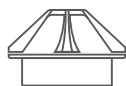

X.56.0009

# S.120 - Slim Lift



Galandage Multi-rail

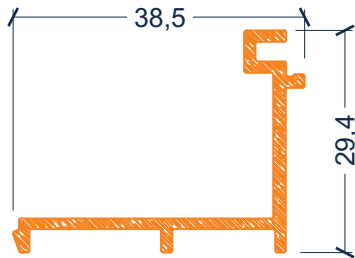

S.120.912

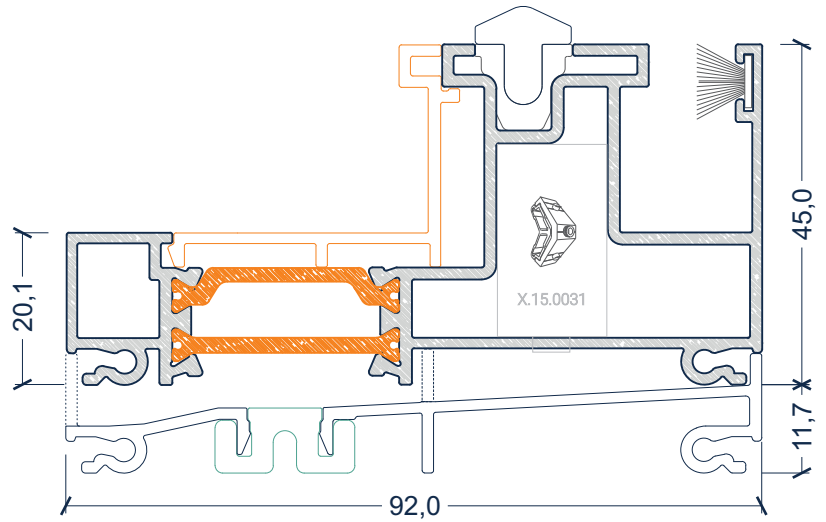

S.120.111

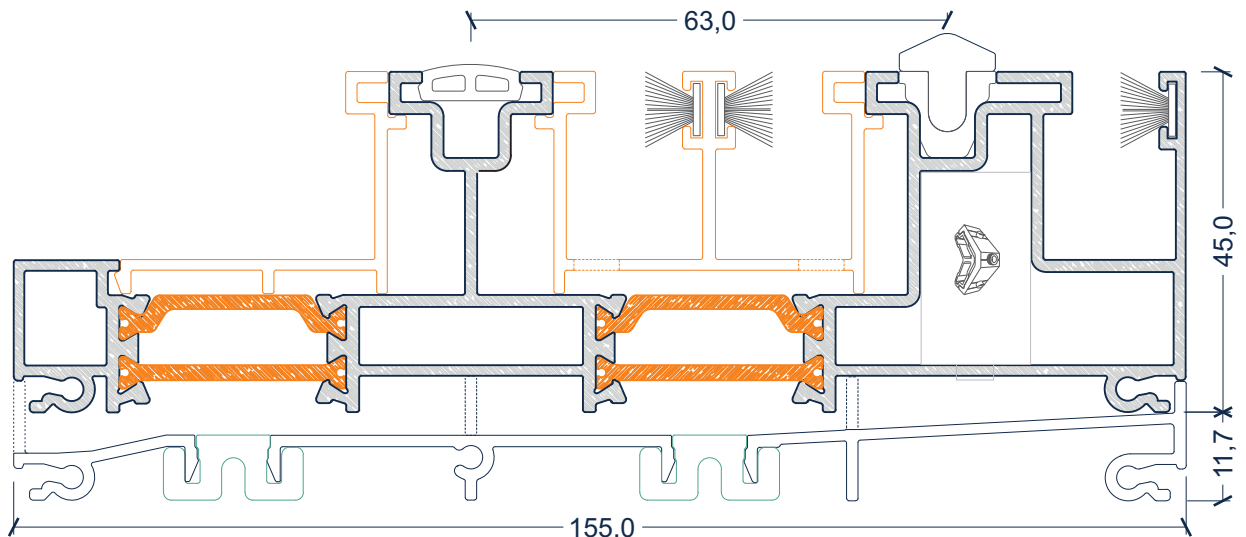

S.120.112

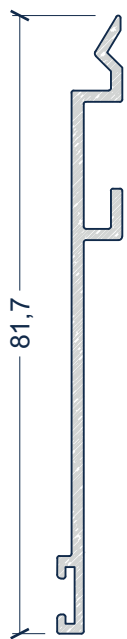

S.120.413

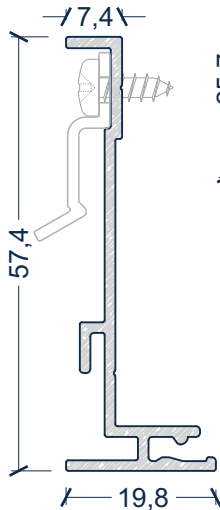

S.120.412

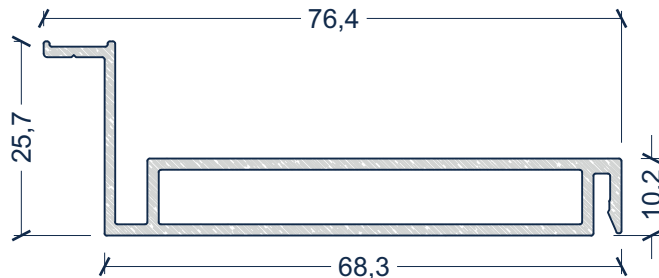

S.120.415

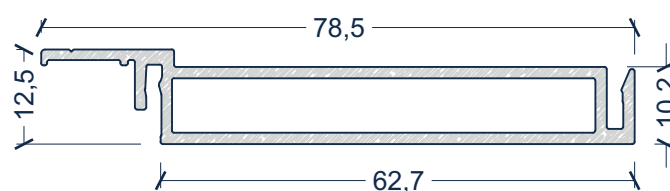

S.120.416

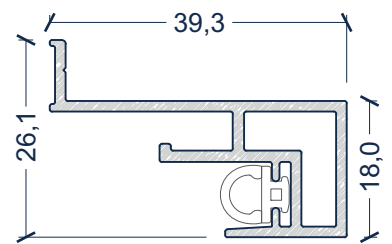

S.120.414

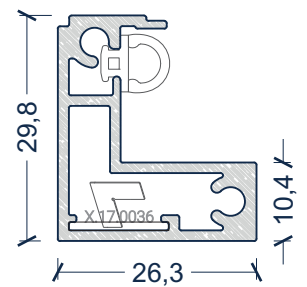

S.120.411



# S.120 - Slim Lift



Móveis Standard e Minimalistas + Bites

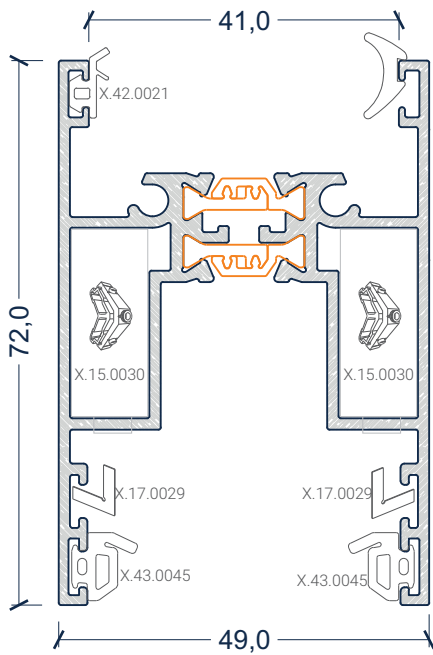

S.120.230

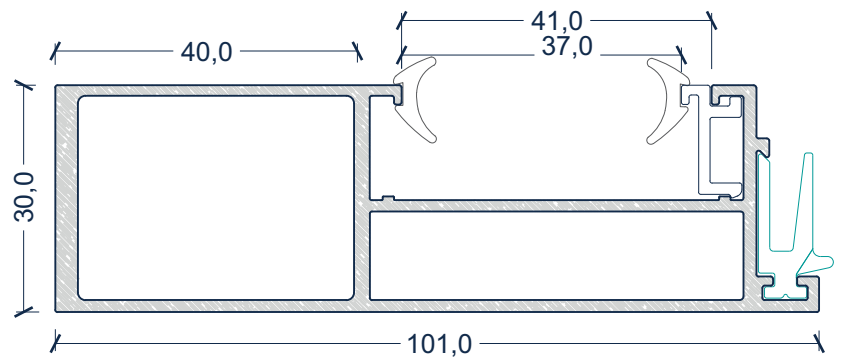

S.120.310

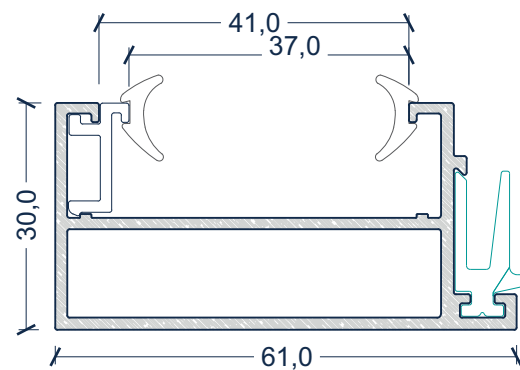

S.120.300

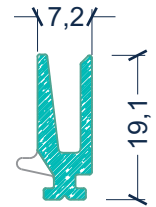

S.120.921

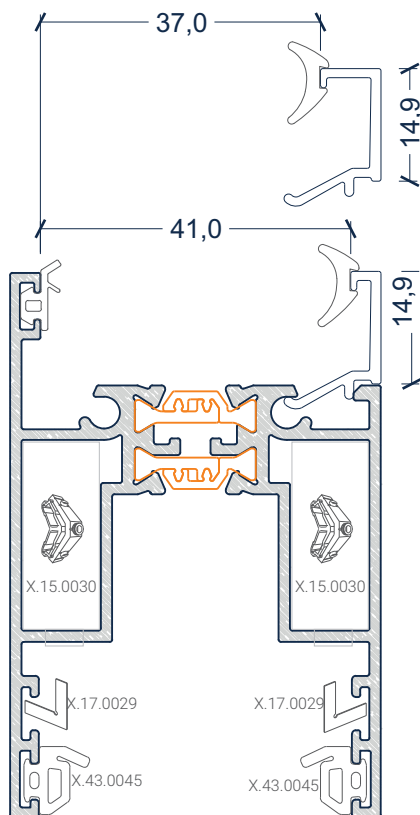

S.120.220

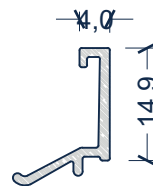

S.120.241



S.120.237



S.120.337

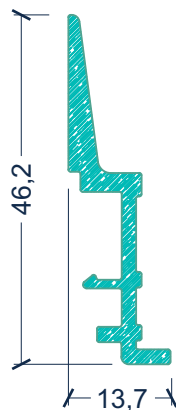

S.120.920

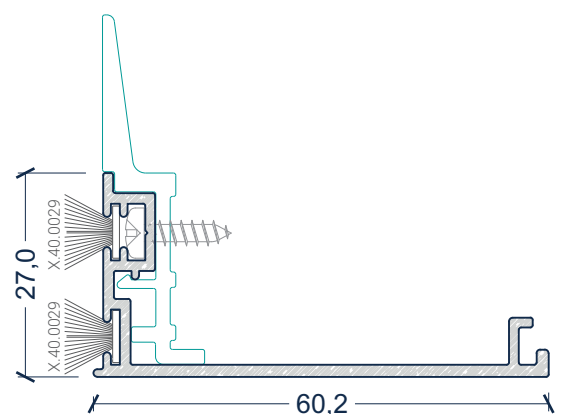

S.120.201

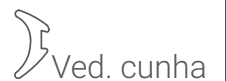
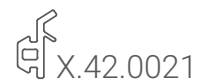
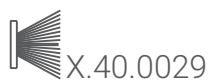
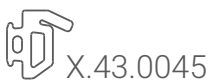

# S.120 - Slim Lift



Perfis de canto, central de 4 folhas e calço multiponto

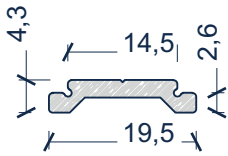

Y.4023

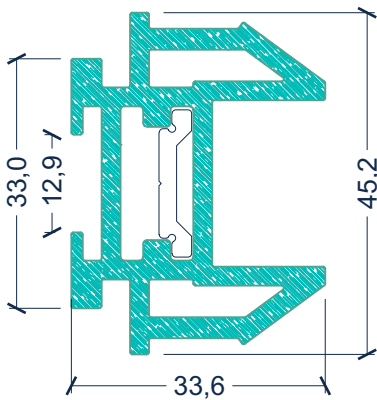
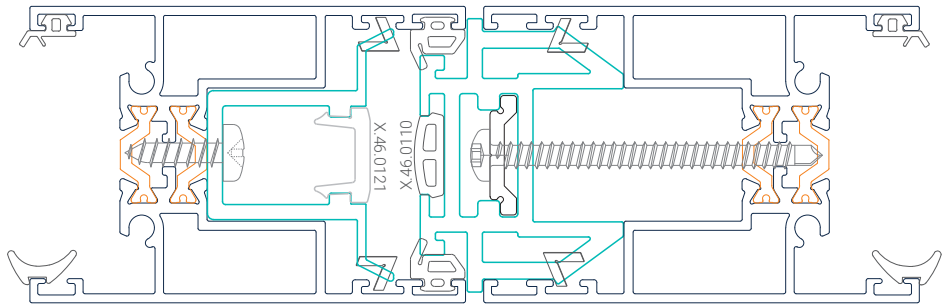

S.120.922

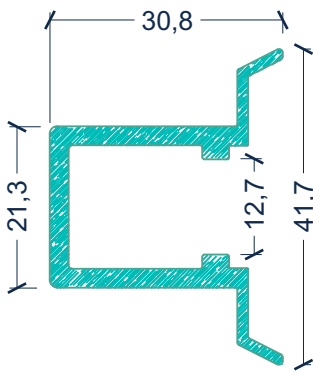
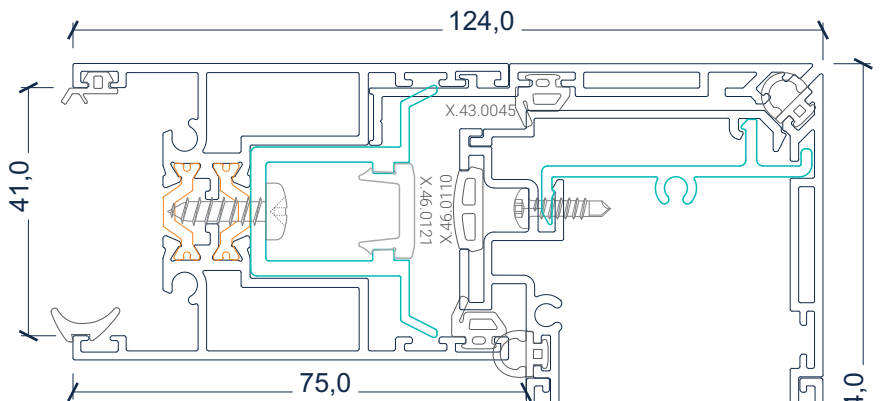

S.120.923

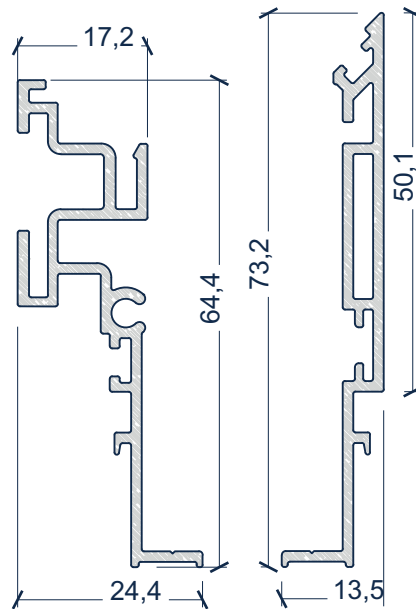

S.120.421

S.120.422

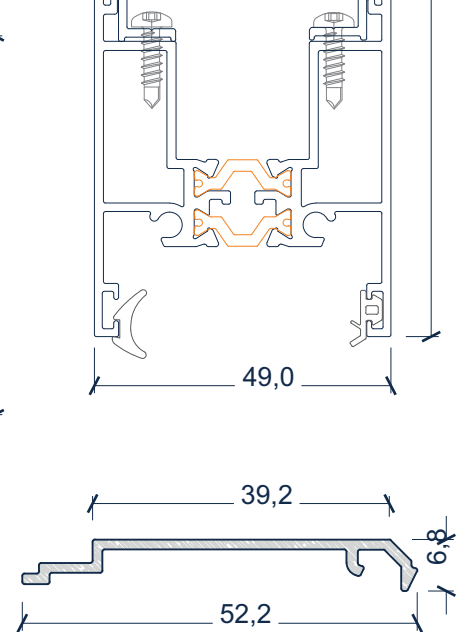

S.120.423

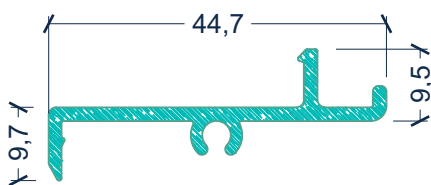

S.120.940

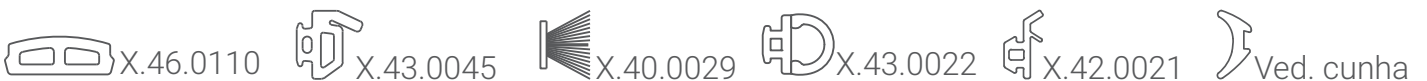

# S.120 - Slim Lift



Perfis versão fixo integrado

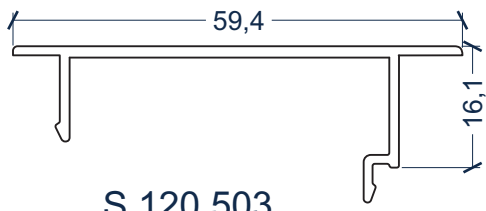

S.120.503



S.120.504

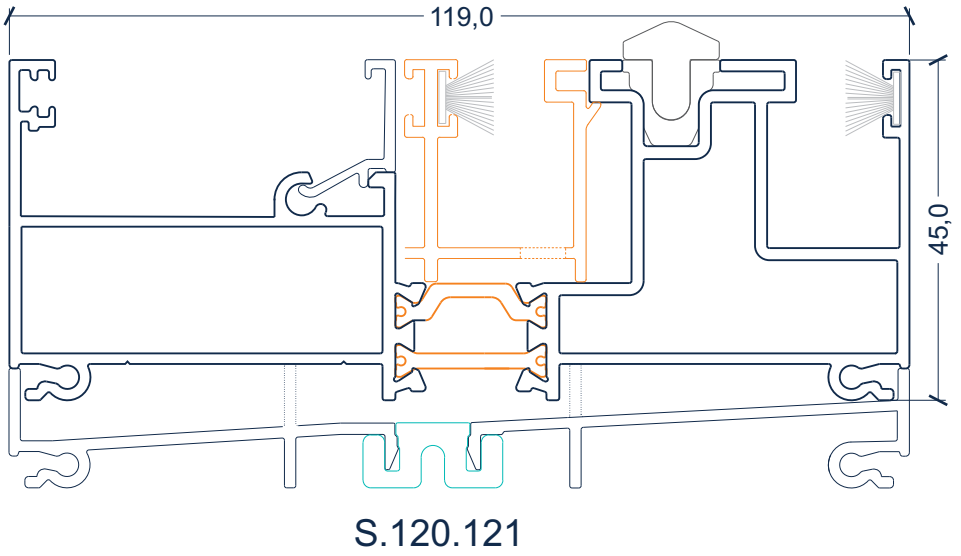

S.120.121

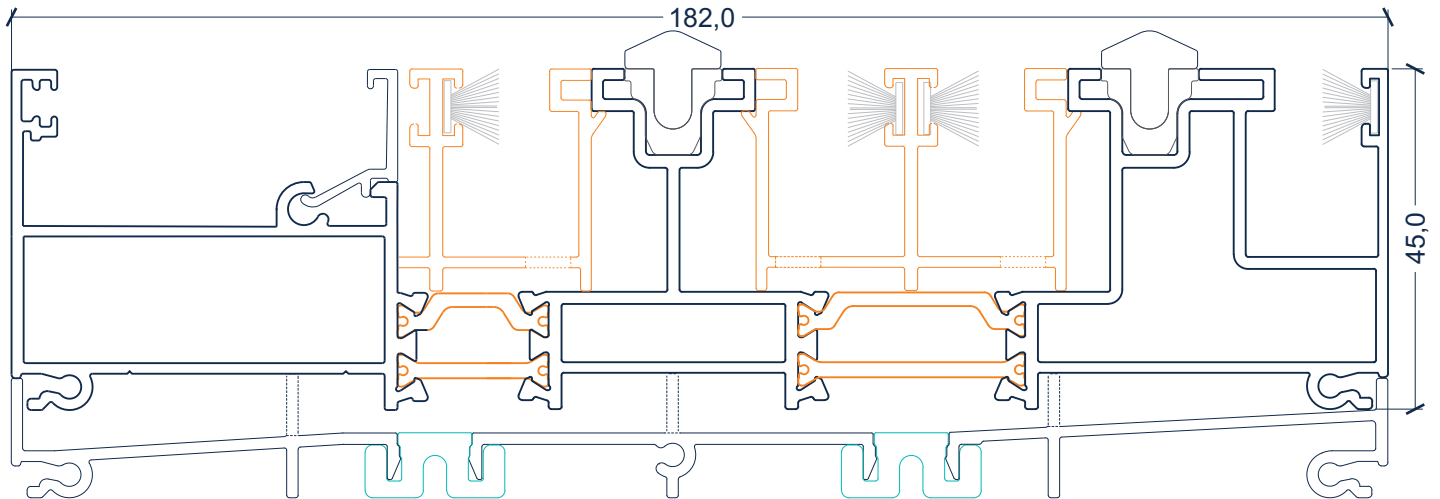

S.120.122

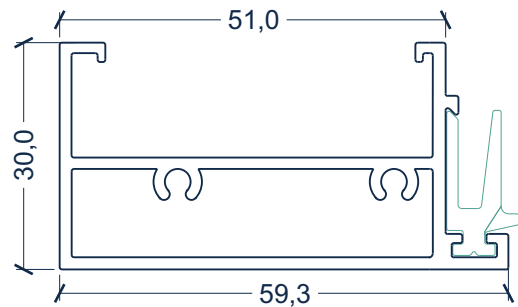
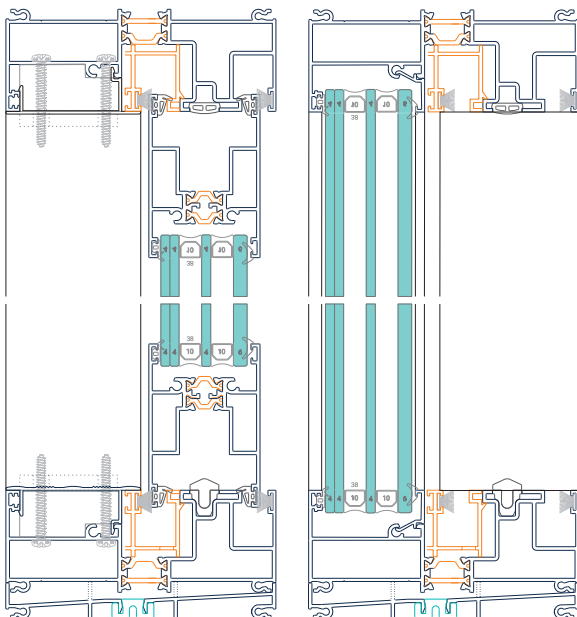

S.120.320

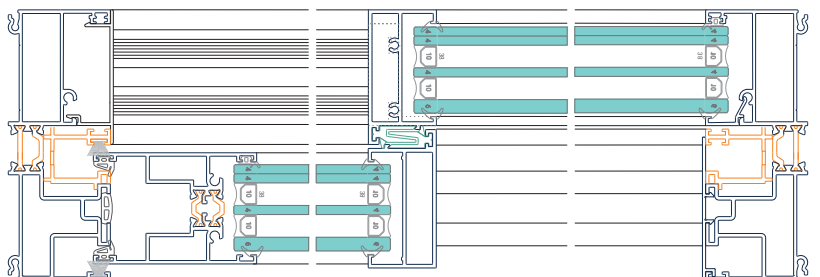





















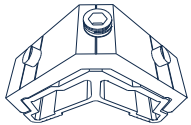
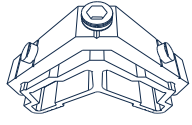
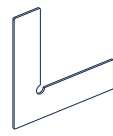
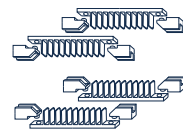
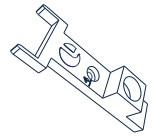
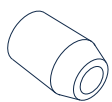

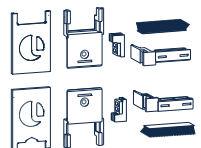

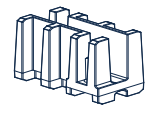

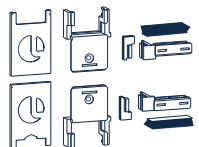
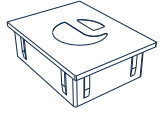
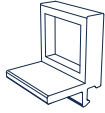
# S.120 - Slim Lift

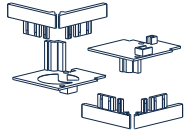

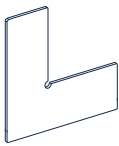
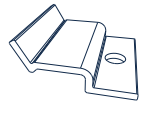
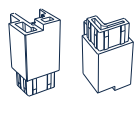
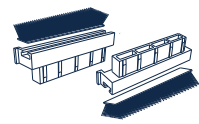
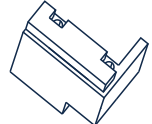
## Vedantes e Acessórios do Sistema

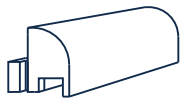
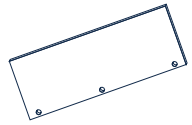
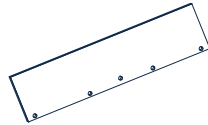
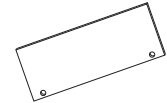
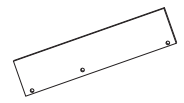
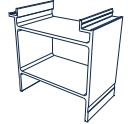
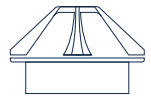
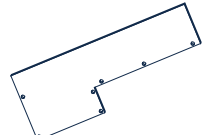
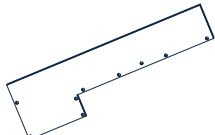
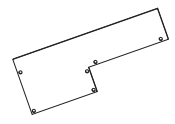
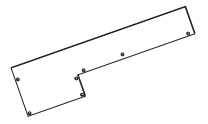
<p>Vedantes</p> 	<p>X.46.0109 Vedante Silent Rail</p> 	<p>X.43.0045 Vedante Folha Elevável</p> 	<p>X.43.0022 Ved. Exterior Galandage</p> 	<p>X.40.0029 Pelúcia Trifin 7,0 x 7,5</p> 	<p>X.46.0110 Vedante Tapa Canal</p> 
<p>X.46.0121 Tapa canal Multiponto</p> 	<p>X.42.0021 Vedante Vidro 2mm</p> 	<p>X.44.0009 Vedante Cunha 2mm</p> 	<p>X.44.0011 Vedante Cunha 3mm</p> 	<p>X.44.0013 Vedante Cunha 4mm</p> 	<p>X.44.0015 Vedante Cunha 5mm</p> 
<p>Gerais</p> 	<p>X.15.0031 Esq. Aperto Aro Fixo</p> 	<p>X.15.0030 Esq. Aperto Aro Móvel</p> 	<p>X.17.0029 Esq. Alinh. Folha 1x6,6</p> 	<p>X.47.0083 Conj. cortaventos inter-rail</p> 	<p>X.52.0199 Guia /Batente lateral</p> 
<p>X.52.0016 Batente lateral de fecho</p> 	<p>X.63.7242 Batente limitador abertura</p> 	<p>Versão standard</p> 	<p>K.52.0205 Kit Guia Central Standard</p> 	<p>Versão folha fixa</p> 	<p>X.63.5219 Apoio para folha fixa</p> 
<p>Versão minimalista</p> 	<p>K.52.0206 Kit Guia Central Minimal.</p> 	<p>X.56.0083 Tampa S.120.310</p> 	<p>X.52.0204 Complemento do bite</p> 	<p>Abertura de canto</p> 	<p>X.56.0084 Kit de remate do Canto</p> 
<p>Versão galandage</p> 	<p>X.17.0036 Esq. Alinh. Galand. 1x12,7</p> 	<p>X.53.0010 Mola Fixação S.120.413</p> 	<p>X.52.0201 Topo Exterior Galandage</p> 	<p>K.52.0207 Topo Multifolha Galand.</p> 	<p>X.18.0041 União Montante de fixo</p> 
<p>Drenagem e rejingot</p> 	<p>X.52.0171 Goteira c/ Defletor</p> 	<p>X.56.0094 Tapa Rejingot Bi-rail</p> 	<p>X.56.0096 Tapa Rejingot Tri-rail</p> 	<p>X.56.0098 T. Rejingot Galand. 1 rail</p> 	<p>X.56.0100 T. Rejing. Galand. bi-rail</p> 
<p>K.54.0106 Suporte grelha escoador</p> 	<p>X.56.0009 Ralo escoamento 50mm</p> 	<p>X.56.0093 Tapa Rejing/Escoad. Bi-rail</p> 	<p>X.56.0095 Tapa Rejingot/Esc. Tri-rail</p> 	<p>X.56.0097 T. Rej/Esc. Galand. 1 rail</p> 	<p>X.56.0099 T. Rej/Esc. Galand. bi-rail</p> 

# S.120 - Slim Lift



## Acessórios de Manobra (Correr em linha)

Rolamentos

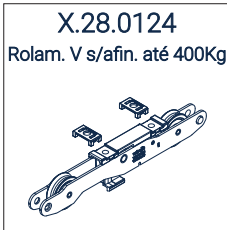
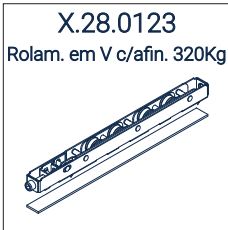
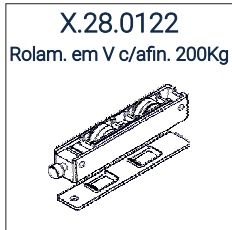

Fechaduras  
certific. americana



Fechaduras  
certific. eropeia

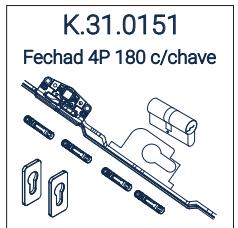
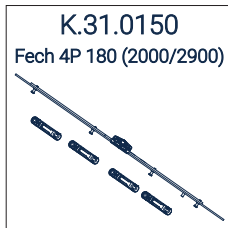
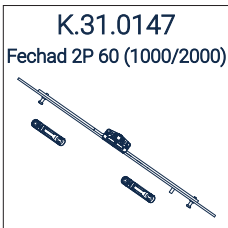
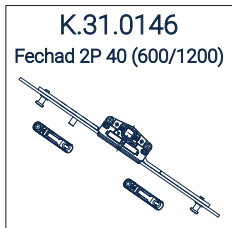

Cremones  
linha Twenty  
(movimento de 20°)

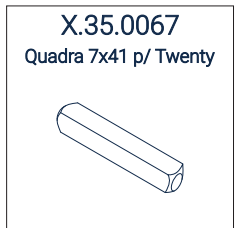
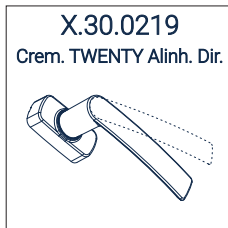
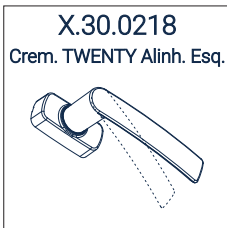
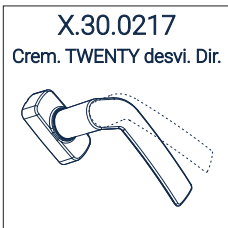
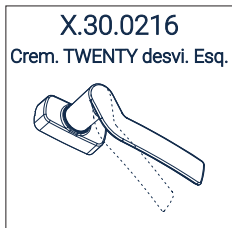

Cremones  
linha Eos  
(movimento de 90°)

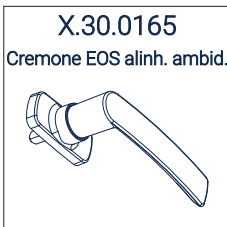

Fechos  
minimalistas

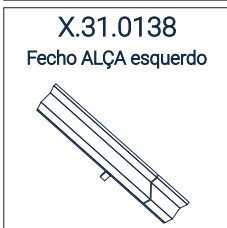

Fechos  
de pega em Asa













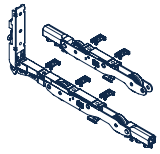
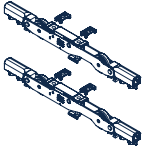

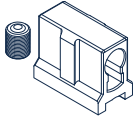
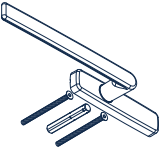
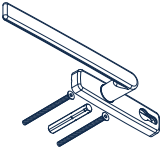
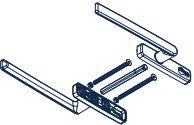
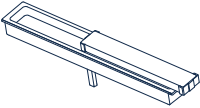
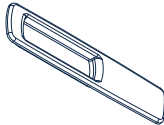
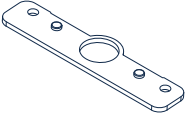

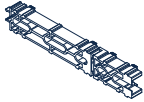
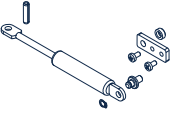
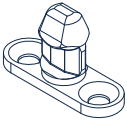
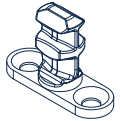

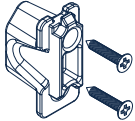
Fechos  
de Embutir

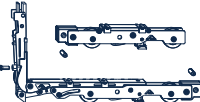
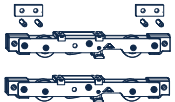
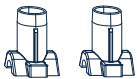

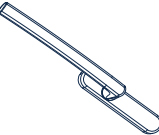
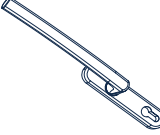
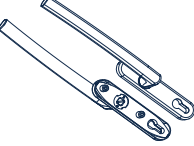
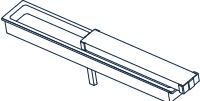
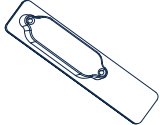
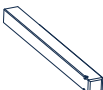
# S.120 - Slim Lift

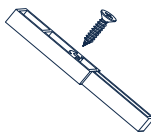
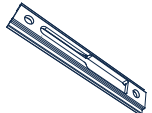

## Acessórios de Manobra (Elevatórios)

<p>Acessórios Jogo Elevavel "Luce" (Fapin)</p> 	<p>X.63.5223 Conj. patins elev. 250kg</p> 	<p>X.63.5224 Conj. patins suplem.400kg</p> 	<p>Vareta para ligação de patins</p>  <p>X.63.5200 - 1000mm - 730 a 1650 X.63.5201 - 1400mm - 1650 a 2050 X.63.5202 - 1800mm - 2050 a 2450 X.63.5203 - 2700mm - 2450 a 3400</p>		<p>X.63.5222 Guia Transmissão patins</p> 																		
<p>X.63.5213 Cremone elevável Luce</p> 	<p>X.63.5221 Cremone elevável c/chave</p> 	<p>X.63.5215 Cremone duplo elevável</p> 	<p>K.63.2236 Cremone Unha elevavel</p> 	<p>X.63.5214 Concha externa cremone</p> 	<p>X.63.5220 Contra-placa cremone elev.</p> 																		
<p>Haste Elevavel c/ cremone a 400mm</p>  <p>X.63.5204 - 1096mm - 810 a 1200 X.63.5205 - 1696mm - 1175 a 1800</p>		<p>Haste Elevavel c/ cremone a 1000mm</p>  <p>X.63.5206 - 2046mm - 1775 a 2150 X.63.5207 - 2296mm - 1925 a 2400 X.63.5208 - 2646mm - 2325 a 2750</p>		<p>X.63.5209 Calço Haste Elevável</p> 	<p>X.63.5216 Auxiliar manobra soft lift</p> 																		
<p>X.63.5210 Ponto fecho elevável</p> 	<p>X.63.5211 Ponto fecho p/ventilação</p> 	<p>Ferramentas</p> 		<p>X.91.0009 Gabarito p/ p. fecho elev.</p> 																			
<p>Acessórios Jogo Elevavel "Design Locking" (Roto Frank)</p> 	<p>X.63.7238 Conj. patins elev. 200kg</p> 	<p>X.63.7239 Conj. patins suplem. 400kg</p> 	<p>X.63.7258 Apoio descanso de patins</p> 	<p>Vareta para ligação de patins</p>  <table border="1"> <thead> <tr> <th></th> <th>s/patins suplem</th> <th>c/patins suplem</th> </tr> </thead> <tbody> <tr> <td>X.63.7243 - 895mm</td> <td>&lt; 1400mm</td> <td>&lt; 1900mm</td> </tr> <tr> <td>X.63.7244 - 1200mm</td> <td>1400 a 1700</td> <td>1900 a 2200</td> </tr> <tr> <td>X.63.7245 - 1500mm</td> <td>1700 a 2000</td> <td>2200 a 2500</td> </tr> <tr> <td>X.63.7246 - 1800mm</td> <td>2000 a 2300</td> <td>2500 a 2800</td> </tr> <tr> <td>X.63.7247 - 2300mm</td> <td>&gt; 2300 mm</td> <td>&gt; 2800mm</td> </tr> </tbody> </table>			s/patins suplem	c/patins suplem	X.63.7243 - 895mm	< 1400mm	< 1900mm	X.63.7244 - 1200mm	1400 a 1700	1900 a 2200	X.63.7245 - 1500mm	1700 a 2000	2200 a 2500	X.63.7246 - 1800mm	2000 a 2300	2500 a 2800	X.63.7247 - 2300mm	> 2300 mm	> 2800mm
	s/patins suplem	c/patins suplem																					
X.63.7243 - 895mm	< 1400mm	< 1900mm																					
X.63.7244 - 1200mm	1400 a 1700	1900 a 2200																					
X.63.7245 - 1500mm	1700 a 2000	2200 a 2500																					
X.63.7246 - 1800mm	2000 a 2300	2500 a 2800																					
X.63.7247 - 2300mm	> 2300 mm	> 2800mm																					
<p>X.63.7255 Cremone elevavel simples</p> 	<p>X.63.7260 Crem. elev. simp. c/chave</p> 	<p>K.63.7262 Crem. elev. duplo c/chave</p> 	<p>K.63.2236 Cremone Unha elevavel</p> 	<p>X.63.7256 Concha Exter. crem. simp.</p> 	<p>X.63.7257 Quadra 10mm p/ cremone</p> 																		
<p>X.63.7259 Parafusos p/ cremone</p> 	<p>Haste Design Locking (Basic) - 300kg</p>  <p>Cremone a 965mm</p> <p>X.63.7248 - 2185 mm - Folhas de 1800 a 2200 mm X.63.7249 - 2375 mm - Folhas de 2200 a 2600 mm X.63.7250 - 3000 mm - Folhas de 2600 a 3100 mm</p>		<p>Haste Design Locking (Soft Lift) - 400kg</p>  <p>Cremone a 965mm</p> <p>X.63.7251 - 2185 mm - Folhas de 1800 a 2200 mm X.63.7252 - 2375 mm - Folhas de 2200 a 2600 mm X.63.7253 - 3000 mm - Folhas de 2600 a 3100 mm</p>		<p>X.63.7241 Conjunto calços da haste</p> 																		
<p>X.63.7240 Calço patim/haste</p> 	<p>X.33.0155 P. fecho Design Locking</p> 	<p>X.63.7254 Ponto fecho de ventilação</p> 																					

# S.120 - Slim Lift



## Plano de Drenagem



Operações de fresa 8 mm  
rasgos de 40 mm

Rasgos de drenagem interior da soleira		LV < 1500	1500 < LV < 2800	2800 < LV < 4100	4100 < LV < 5400	5400 < LV < 6700	6700 < LV < 8000
(A) Rasgos laterais	Quant.	2					
Centrado a 100 mm das extremidades							
(B) Rasgos intermédios	Quant.	0	1	2	3	4	5
Posição	Posição	(LV-200)/2	(LV-200)/3	(LV-200)/4	(LV-200)/5	(LV-200)/6	(LV-200)/6

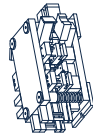
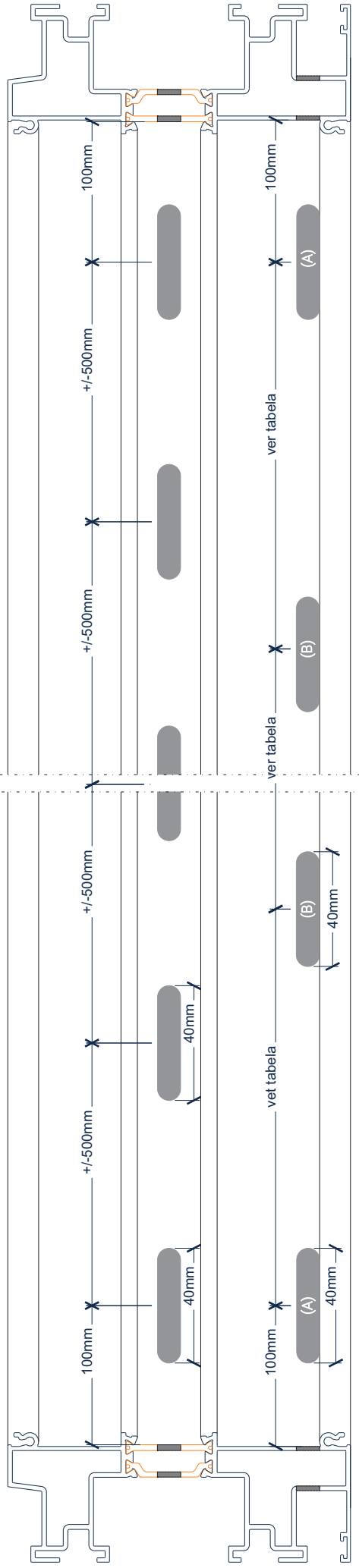

Operação de cunho para soluções sem grelha (com grelha, usar o perfil S.120.430, já maquinado)

Rasgos de drenagem para goteiras		LV < 1400	1400 < LV < 2000	2000 < LV < 2600	2600 < LV < 3200	3200 < LV < 3800	3800 < LV < 4400	4400 < LV < 5000	5000 < LV < 5600	5600 < LV < 6200	6200 < LV < 6800	6800 < LV < 7400
(C) Rasgos laterais	Quant.	2										
Centrado a 100 mm das extremidades												
(D) Rasgos intermédios	Quant.	1	2	3	4	5	6	7	8	9	10	11
Posição	Posição	(LV - 200)/2	(LV-200)/3	(LV-200)/4	(LV-200)/5	(LV-200)/6	(LV-200)/7	(LV-200)/8	(LV-200)/9	(LV-200)/10	(LV-200)/11	(LV-200)/12

S.120.431  
S.120.435

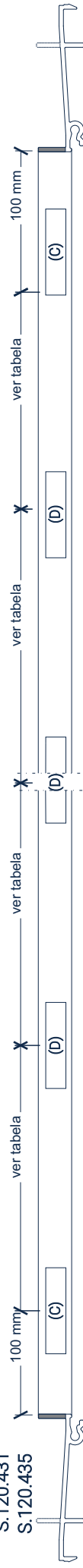

**Importante:** Na Galandage considera-se «Largura do Vão» (LV) a parte exposta do caixilho, não inclui a parte embutida, pelo que se deverá ter atenção aos rasgos da drenagem do perfil S.120.434

# S.120 - Slim Lift

Esquema de drenagem (consultar plano de drenagem)

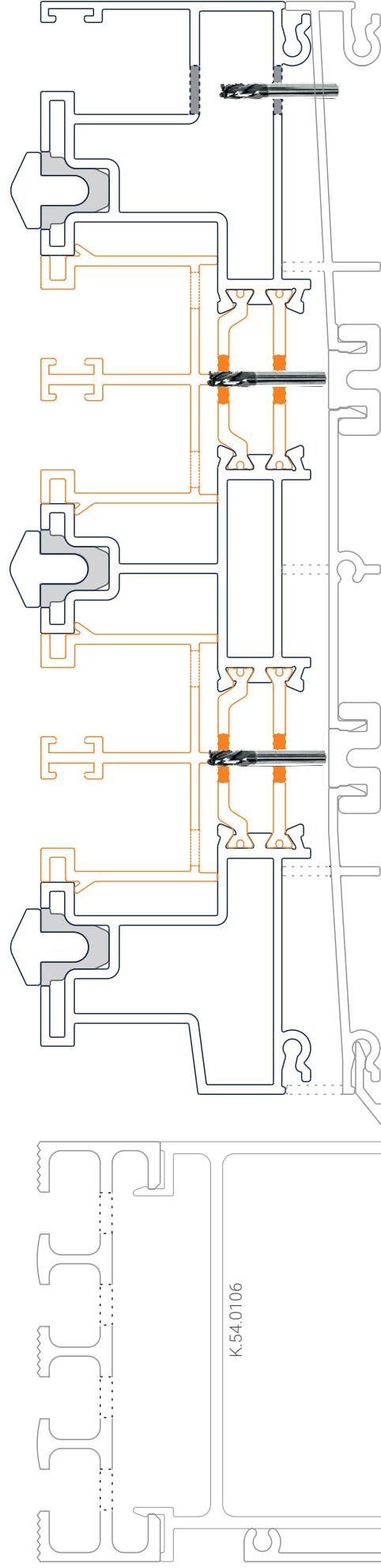

Com Rejingot

Sem Rejingot

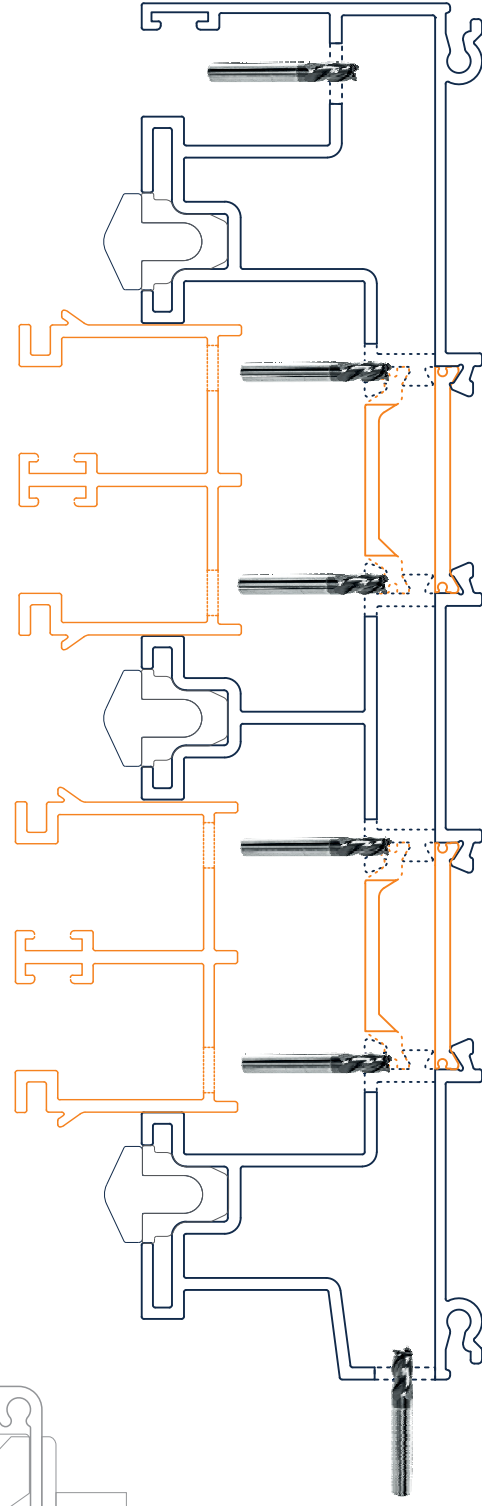

operação de fresa

# S.120 - Slim Lift



## Consumos e Medidas de Corte

Elevável ou Correr Vista standard

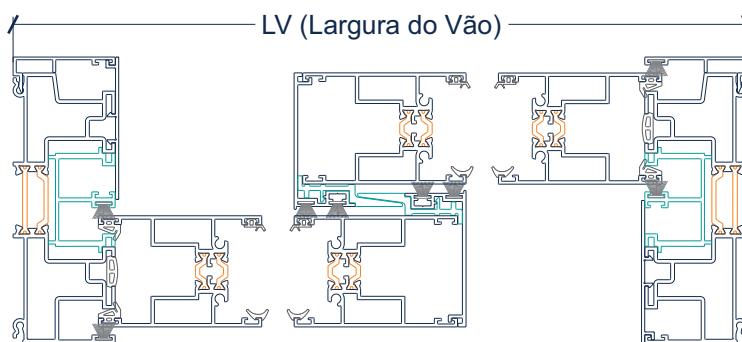
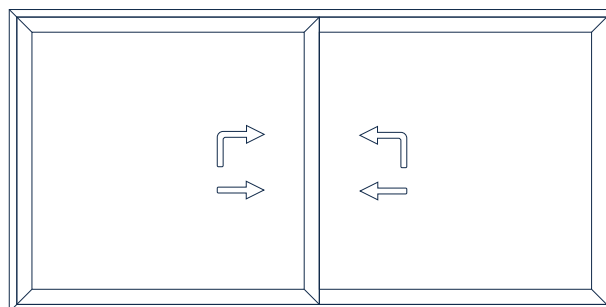
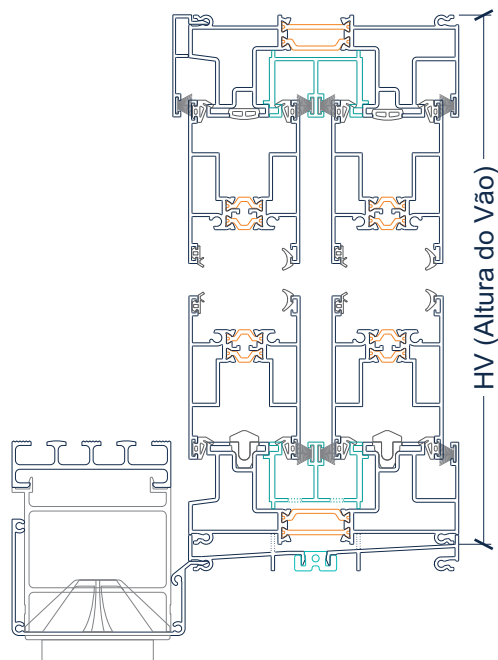

As medidas de corte apresentadas são orientativas, pelo que deverão ser verificadas em obra

Ícone	Larguras			Alturas			Maquinações*	
	medidas	tipo de corte	pcs.	medidas	tipo de corte	pcs.	operações cunho	operações fresa
S.120.100	LV - 90		2					
S.120.102	LV		2	HV		2	Esquadros	Drenagem
S.120.210			4	HV-75		4	Esquadros	
S.120.200	(LV-6,8)/2		4	HV-137,6		2	Furo Guia	
S.120.201			4	HV-219		4		
S.120.237 <sup>(1)</sup>			4					
S.120.241 <sup>(1)</sup>	(LV-235,2)/2		4					
S.120.501	LV		1	HV		2		
S.120.910	LV-31,2		1	HV-31,2		2		
S.120.911	LV-31,2		1					
S.120.920				HV-137,6		2		
S.120.923 (c)				HV-222		2(c)		
S.120.502 <sup>(#)</sup>				HV-90		2		
S.120.430 <sup>(#)</sup>								
S.120.431 <sup>(#)</sup>	LV		1				Drenag.(g)	
S.120.432 <sup>(#)</sup>	LV		1					
S.120.930 <sup>(#)</sup>	LV		1					
Y.0301 <sup>(#)</sup>	LV		1					
Y.0302 <sup>(#)</sup>	LV/(a)		(a)					

Acessórios				
Vedantes	LF	AF	LM	AM
	X.46.0109	2		
	X.46.0110	2	2	
	X.43.0045			8(b) 4
	X.40.0029	7	4	8(c) 4
	X.42.0021			4 4
	Ved.cunha <sup>(3)</sup>			4 4
Acessórios do Sistema				
	X.15.0031		8	
	X.15.0030		16	
	X.17.0029		16	
	X.47.0083		1	
	K.52.0205		2	
	X.52.0199		2	
	X.52.0016		2	
	X.52.0171		(g)	
	K.54.0106 <sup>(#)</sup>		3x(a)	
	X.56.0009 <sup>(#)</sup>		1	
Rolamentos				
	X.28.0122			
	X.28.0123		4	
	X.28.0124			

(\*)-Ver pag. mecanizações; (#)-Soluções Opcionais; (1)-Se móvel=S.120.200; (2)-Se cx vidro=37mm; (3)-Ver pag. acessórios;

(a)=LV arredondada a mts; (b)-Se Elevável; (c)-Se de Correr; (d)=Nº pcs S.120.310; (e)Folhas laterais; (f)Folha Central; (g)-Ver Plano de drenagem;

# S.120 - Slim Lift



## Medidas de Corte e Consumos

Elevável ou Correr Vista standard

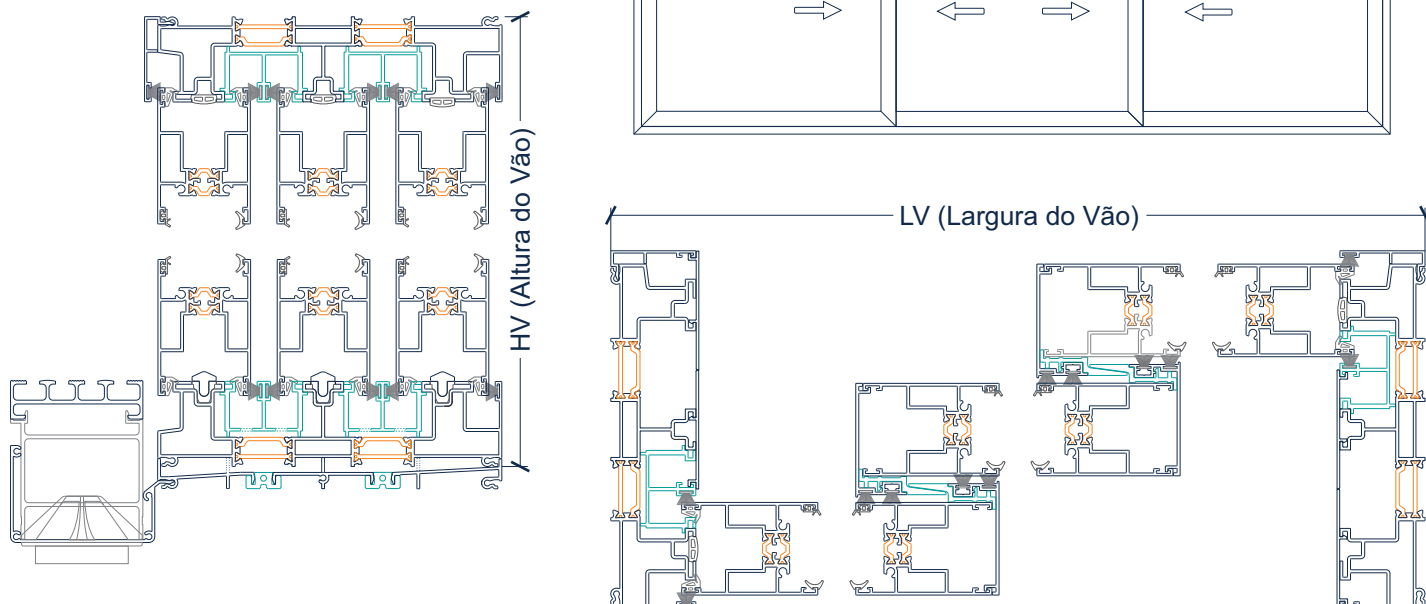

As medidas de corte apresentadas são orientativas, pelo que deverão ser verificadas em obra

Código	Ícone	Larguras			Alturas			Maquinações*	
		medidas	tipo de corte	pcs.	medidas	tipo de corte	pcs.	operações cunho	operações fresa
S.120.100		LV - 90		3					
S.120.103		LV		2	HV		2	Esquadros	Drenagem
S.120.210		(LV+61,4)/3		6	HV-75		6	Esquadros	
S.120.200									
S.120.201					HV-137,6		4	Furo Guia	
S.120.237 <sup>(1)</sup>									
S.120.241 <sup>(1)</sup>		(LV-311,2)/3		6	HV-219		6		
S.120.501		LV		1	HV		2		
S.120.910		LV-31,2		1	HV-31,2		2		
S.120.911		LV-31,2		1					
S.120.920					HV-137,6		4		
S.120.923 (c)					HV-137,6		2		
S.120.502 <sup>(#)</sup>					HV-90		4		
S.120.430 <sup>(#)</sup>									
S.120.431 <sup>(#)</sup>		LV		1				Drenag.(g)	
S.120.432 <sup>(#)</sup>		LV		1					
S.120.433 <sup>(#)</sup>		LV		1					
S.120.930 <sup>(#)</sup>		LV		2					
Y.0301 <sup>(#)</sup>		LV		1					
Y.0302 <sup>(#)</sup>		LV/(a)		(a)					

Acessórios					
Vedantes		LF	AF	LM	AM
	X.46.0109	3			
	X.46.0110	3	2		
	X.43.0045			12(b)	4
	X.40.0029	11	4	12(c)	8
	X.42.0021			6	6
	Ved.cunha <sup>(3)</sup>			6	6
Acessórios do Sistema					
	X.15.0031			8	
	X.15.0030			24	
	X.17.0029			24	
	X.47.0083			2	
	K.52.0205			4	
	X.52.0199			2	
	X.52.0016			2	
	X.52.0171			(g)	
	K.54.0106 <sup>(#)</sup>			3x(a)	
	X.56.0009 <sup>(#)</sup>			1	
Rolamentos					
	X.28.0122				
	X.28.0123			6	
	X.28.0124				

(\*)-Ver pag. mecanizações; (#)-Soluções Opcionais; (1)-Se móvel=S.120.200; (2)-Se cx vidro=37mm; (3)-Ver pag. acessórios;

(a)=LV arredondada a mts; (b)-Se Elevável; (c)-Se de Correr; (d)=Nº pcs S.120.310; (e)Folhas laterais; (f)Folha Central; (g)-Ver Plano de drenagem;

# S.120 - Slim Lift



## Medidas de Corte e Consumos

Elevável ou Correr Vista standard

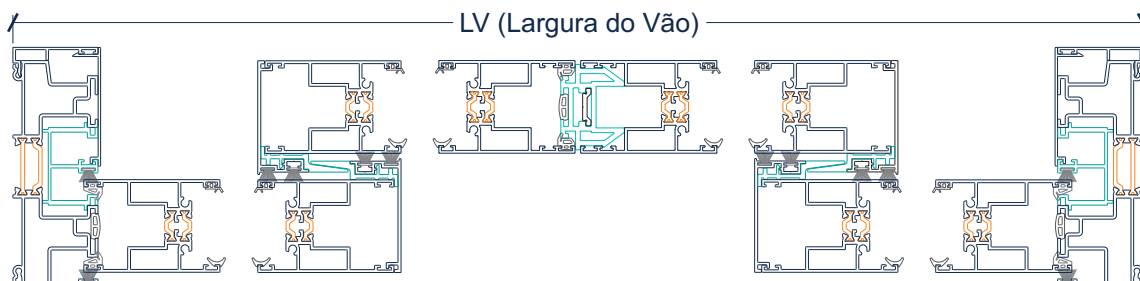
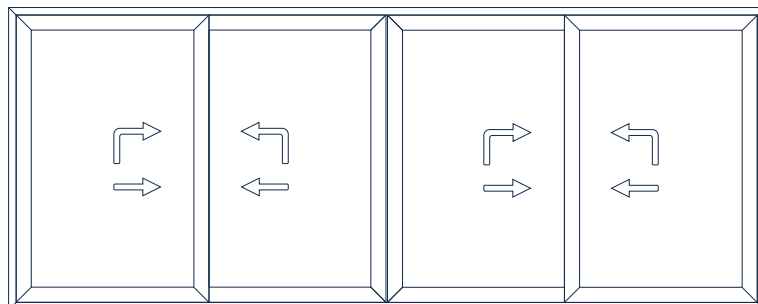
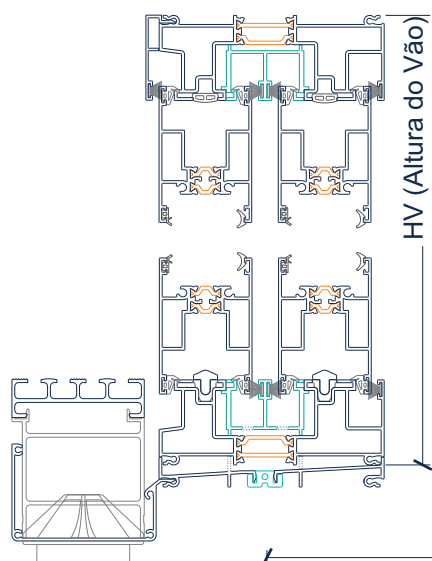

As medidas de corte apresentadas são orientativas, pelo que deverão ser verificadas em obra

Ícone	Larguras			Alturas			Maquinações*	
	medidas	tipo de corte	pcs.	medidas	tipo de corte	pcs.	operações cunho	operações fresa
S.120.100	LV - 90		2					
S.120.102	LV		2	HV		2	Esquadros	Drenagem
S.120.210	(LV+58,4)/4		8	HV-75		8	Esquadros	
S.120.200								
S.120.201				HV-137,6		4	Furo Guia	
S.120.237(1)								
S.120.241(1)	(LV-398,4)/4		8	HV-219		4		
S.120.501	LV		1	HV		2		
S.120.910	LV-31,2		1	HV-31,2		2		
S.120.911	LV-31,2		1					
S.120.920				HV-137,6		4		
S.120.922				HV-75		1		
Y.4023				HV-75		1		
S.120.923 (c)				HV-222		3		
S.120.502 (#)				HV-90		2		
S.120.430 (#)								
S.120.431 (#)	LV		1				Drenag.(g)	
S.120.432 (#)	LV		1					
S.120.930 (#)	LV		1					
Y.0301 (#)	LV		1					
Y.0302 (#)	LV/(a)		(a)					

Acessórios					
Vedantes		LF	AF	LM	AM
	X.46.0109	2			
	X.46.0110	2	2		
	X.43.0045			16(b)	6
	X.40.0029	7	4	16(c)	8
	X.42.0021			8	8
	Ved.cunha <sup>(3)</sup>			8	8
Acessórios do Sistema					
	X.15.0031			8	
	X.15.0030			32	
	X.17.0029			32	
	X.47.0083			3	
	K.52.0205			4	
	X.52.0199			4	
	X.52.0016			4	
	X.52.0171			(g)	
	K.54.0106(#)			3x(a)	
	X.56.0009(#)			1	
Rolamentos					
	X.28.0122				
	X.28.0123			8	
	X.28.0124				

(\*)-Ver pag. mecanizações; (#)-Soluções Opcionais; (1)-Se móvel=S.120.200; (2)-Se cx vidro=37mm; (3)-Ver pag. acessórios;

(a)=LV arredondada a mts; (b)-Se Elevável; (c)-Se de Correr; (d)=Nº pcs S.120.310; (e)Folhas laterais; (f)Folha Central; (g)-Ver Plano de drenagem;



# S.120 - Slim Lift



## Medidas de Corte e Consumos

Elevável ou Correr Vista minimalista

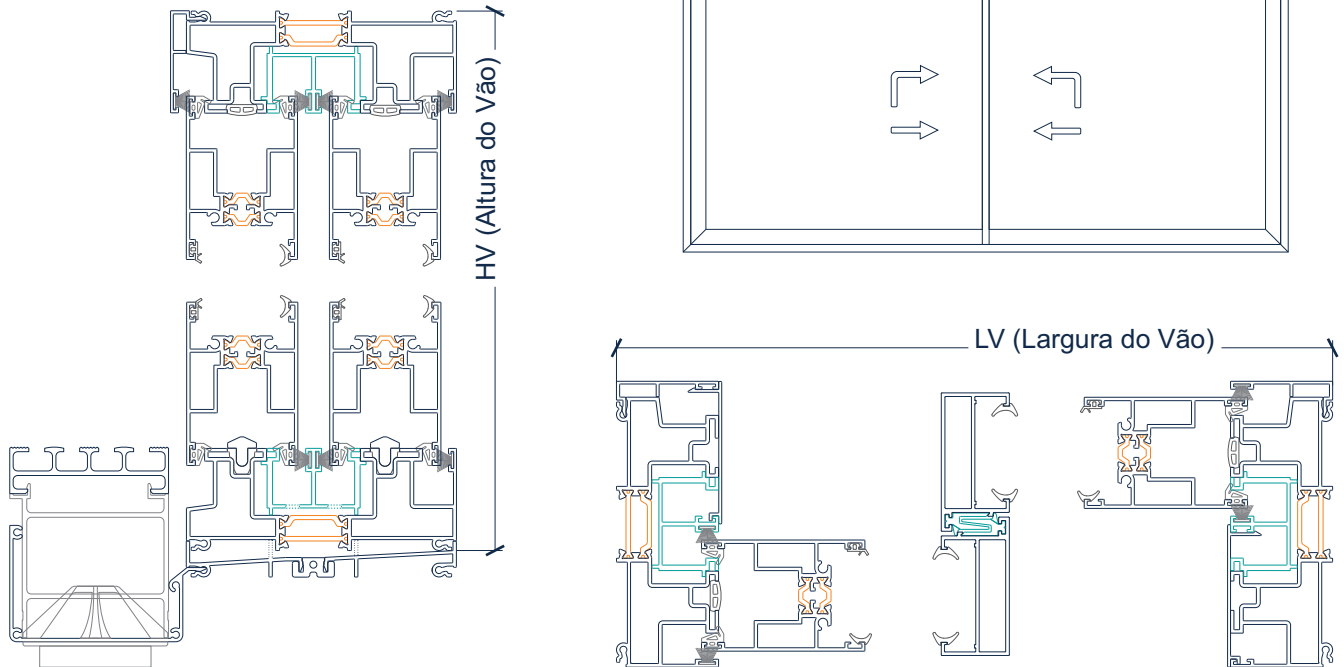

As medidas de corte apresentadas são orientativas, pelo que deverão ser verificadas em obra

Ícone	Larguras			Alturas			Maquinações*	
	medidas	tipo de corte	pcs.	medidas	tipo de corte	pcs.	operações cunho	operações fresa
S.120.100	LV - 90		2					
S.120.102	LV		2	HV		2	Esquadros	Drenagem
S.120.210	(LV-75,6)/2		4	HV-75		2	Esquadros	
S.120.200								
S.120.300				HV-137,6		2	Entalhe do móvel e furo do guia	
S.120.310								
S.120.237 <sup>(1)</sup>	(LV-219,2)/2		4	HV- 219		2		
S.120.241 <sup>(1)</sup>				HV- 219		2		
S.120.337 <sup>(2)</sup>								
S.120.501	LV		1	HV		2		
S.120.910	LV - 31,2		1	HV - 31,2		2		
S.120.911	LV - 31,2		1					
S.120.921				HV-137,6		2		
S.120.923 (c)				HV-222		2		
S.120.502 <sup>(#)</sup>				HV-90		2		
S.120.430 <sup>(#)</sup>								
S.120.431 <sup>(#)</sup>	LV		1				Drenag.(g)	
S.120.432 <sup>(#)</sup>	LV		1					
S.120.930 <sup>(#)</sup>	LV		1					
Y.0301 <sup>(#)</sup>	LV		1					
Y.0302 <sup>(#)</sup>	LV/(a)		(a)					

Acessórios				
Vedantes	LF	AF	LM	AM
X.46.0109	2			
X.46.0110	2	2		
X.43.0045			8 (b)	4
X.40.0029	7	4	8 (c)	
X.42.0021			4	2
Ved.cunha <sup>(3)</sup>			4	6
Acessórios do Sistema				
X.15.0031		8		
X.15.0030		8		
X.17.0029		8		
X.47.0083		1		
K.52.0206		2		
X.52.0199		2		
X.52.0016		2		
X.56.0083		2x(d)		
X.52.0171		(g)		
K.54.0106 <sup>(#)</sup>		3x(a)		
X.56.0009 <sup>(#)</sup>		1		
Rolamentos				
X.28.0122				
X.28.0123		4		
X.28.0124				

(\*)-Ver pag. mecanizações; (#)-Soluções Opcionais; (1)-Se móvel=S.120.200; (2)-Se cx vidro=37mm; (3)-Ver pag. acessórios;

(a)=LV arredondada a mts; (b)-Se Elevável; (c)-Se de Correr; (d)=Nº pcs S.120.310; (e)Folhas laterais; (f)Folha Central; (g)-Ver Plano de drenagem;

# S.120 - Slim Lift



## Medidas de Corte e Consumos

Elevável ou Correr Vista minimalista

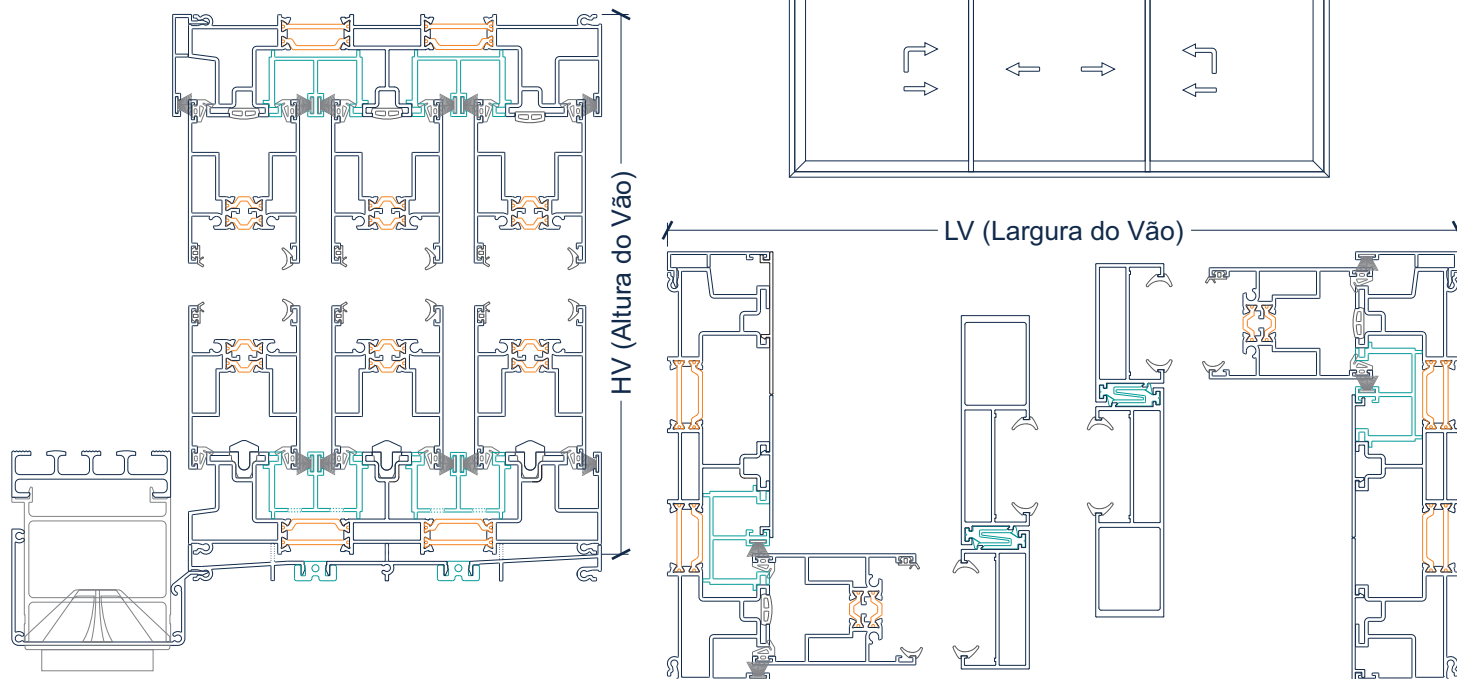

As medidas de corte apresentadas são orientativas, pelo que deverão ser verificadas em obra

Código	Diagrama	Larguras			Alturas			Maquinações*	
		medidas	tipo de corte	pcs.	medidas	tipo de corte	pcs.	operações cunho	operações fresa
S.120.100		LV - 90		3					
S.120.103		LV		2	HV		2	Esquadros	Drenagem
S.120.210		(LV-19,1)/3 (e)		4	HV-75		2	Esquadros	
S.120.200		(LV-190,5)/3 (f)		2					
S.120.300					HV-137,6		4	Entalhe do móvel e furo do guia	
S.120.310									
S.120.237 <sup>(1)</sup>		(LV-234,5)/3 (e)		4	HV-219		2		
S.120.241 <sup>(1)</sup>		(LV-278,8)/3 (f)		2					
S.120.337 <sup>(2)</sup>					HV-219		4		
S.120.501		LV		1	HV		2		
S.120.910		LV-31,2		2					
S.120.911		LV-31,2		2					
S.120.921					HV-137,6		4		
S.120.923 (c)									
S.120.502(#)					HV-90		4		
S.120.430(#)									
S.120.431(#)		LV		1				Drenag.(g)	
S.120.432(#)		LV		1					
S.120.433(#)		LV		1					
S.120.930 (#)		LV		2					
Y.0301 (#)		LV		1					
Y.0302 (#)		LV/(a)		(a)					

Acessórios					
Vedantes		LF	AF	LM	AM
	X.46.0109	3			
	X.46.0110	3	2		
	X.43.0045			8(b)	4
	X.40.0029	11	4	4(b) 12(c)	
	X.42.0021			6	2
	Ved.cunha <sup>(3)</sup>			6	10
Acessórios do Sistema					
	X.15.0031		8		
	X.15.0030		8		
	X.17.0029		8		
	X.47.0083		2		
	K.52.0206		4		
	X.52.0199		2		
	X.52.0016		2		
	X.56.0083		2x(d)		
	X.52.0171		(g)		
	K.54.0106(#)		3x(a)		
	X.56.0009(#)		1		
Rolamentos					
	X.28.0122				
	X.28.0123		6		
	X.28.0124				

(\*)-Ver pag. mecanizações; (#)-Soluções Opcionais; (1)-Se móvel=S.120.200; (2)-Se cx vidro=37mm; (3)-Ver pag. acessórios;

(a)=LV arredondada a mts; (b)-Se Elevável; (c)-Se de Correr; (d)=Nº pcs S.120.310; (e)Folhas laterais; (f)Folha Central; (g)-Ver Plano de drenagem;

# S.120 - Slim Lift



## Medidas de Corte e Consumos

Elevável ou Correr Vista minimalista

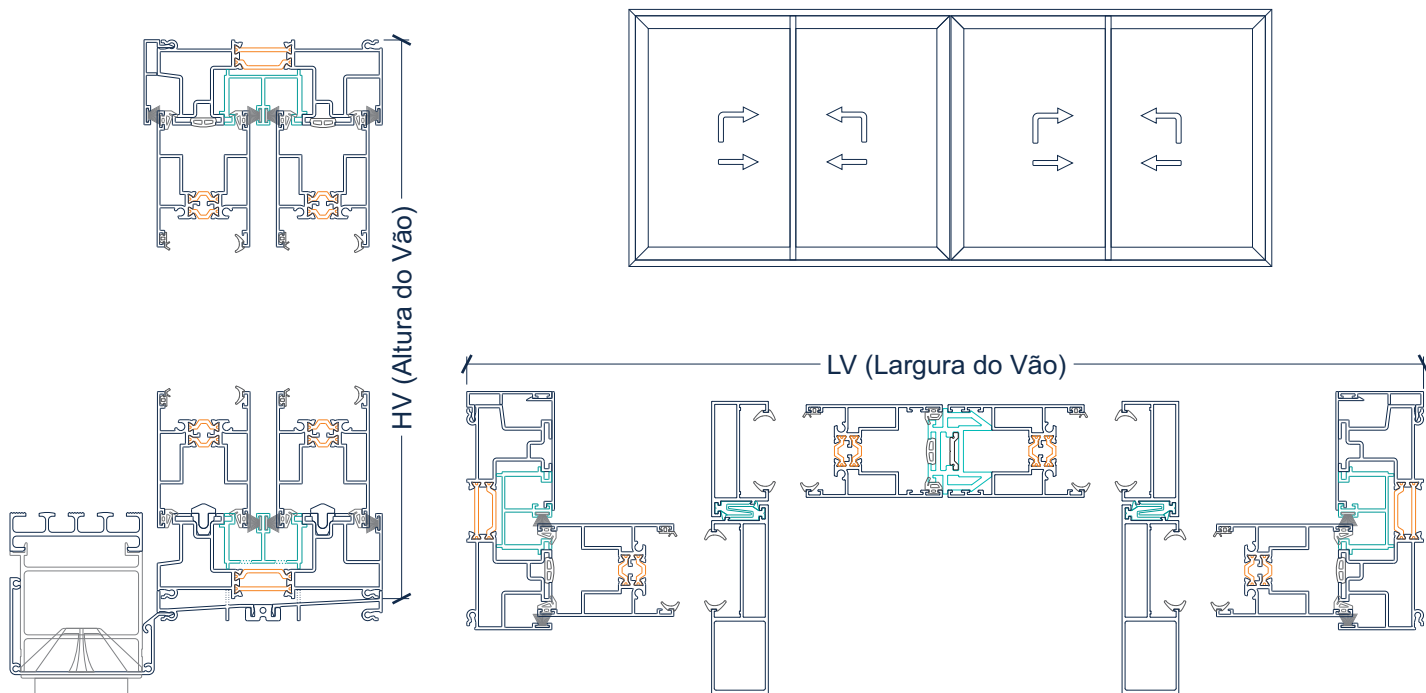

As medidas de corte apresentadas são orientativas, pelo que deverão ser verificadas em obra

Ícone	Larguras			Alturas			Maquinações*	
	medidas	tipo de corte	pcs.	medidas	tipo de corte	pcs.	operações cunho	operações fresa
S.120.100	LV - 90		2					
S.120.102	LV		2	HV		2	Esquadros	Drenagem
S.120.210	(LV-79,2)/4		8	HV-75		4	Esquadros	
S.120.200								
S.120.300				HV-137,6		4	Entalhe do móvel e furo do guia	
S.120.310								
S.120.237 <sup>(1)</sup>	(LV-366,5)/4		8	HV-219		4		
S.120.241 <sup>(1)</sup>								
S.120.337 <sup>(2)</sup>				HV-219		4		
S.120.501								
S.120.910	LV-31,2		1	HV-31,2		2		
S.120.911								
S.120.921				HV-137,6		4		
S.120.923 (c)								
S.120.922				HV-75		1		
Y.4023								
S.120.502 <sup>(#)</sup>				HV-90		2		
S.120.430 <sup>(#)</sup>								
S.120.431 <sup>(#)</sup>	LV		1				Drenag.(g)	
S.120.432 <sup>(#)</sup>								
S.120.930 <sup>(#)</sup>	LV		1					
Y.0301 <sup>(#)</sup>	LV		1					
Y.0302 <sup>(#)</sup>	LV/(a)		(a)					

Acessórios					
Vedantes		LF	AF	LM	AM
	X.46.0109	2			
	X.46.0110	2	2		
	X.43.0045			16(b)	6
	X.40.0029	7	4	16(c)	
	X.42.0021			8	4
	Ved.cunha <sup>(3)</sup>			8	12
Acessórios do Sistema					
	X.15.0031		8		
	X.15.0030		16		
	X.17.0029		16		
	X.47.0083		3		
	K.52.0206		4		
	X.52.0199		3		
	X.52.0016		3		
	X.56.0083		2x (d)		
	X.52.0171		(g)		
	K.54.0106 <sup>(#)</sup>		3x (a)		
	X.56.0009 <sup>(#)</sup>		1		
Rolamentos					
	X.28.0122		8		
	X.28.0123				
	X.28.0124				

(\*)-Ver pag. mecanizações; (#)-Soluções Opcionais; (1)-Se móvel=S.120.200; (2)-Se cx vidro=37mm; (3)-Ver pag. acessórios;

(a)=LV arredondada a mts; (b)-Se Elevável; (c)-Se de Correr; (d)=Nº pcs S.120.310; (e)Folhas laterais; (f)Folha Central; (g)-Ver Plano de drenagem;

# S.120 - Slim Lift



Abertura de canto (folha do canto no rail exterior)

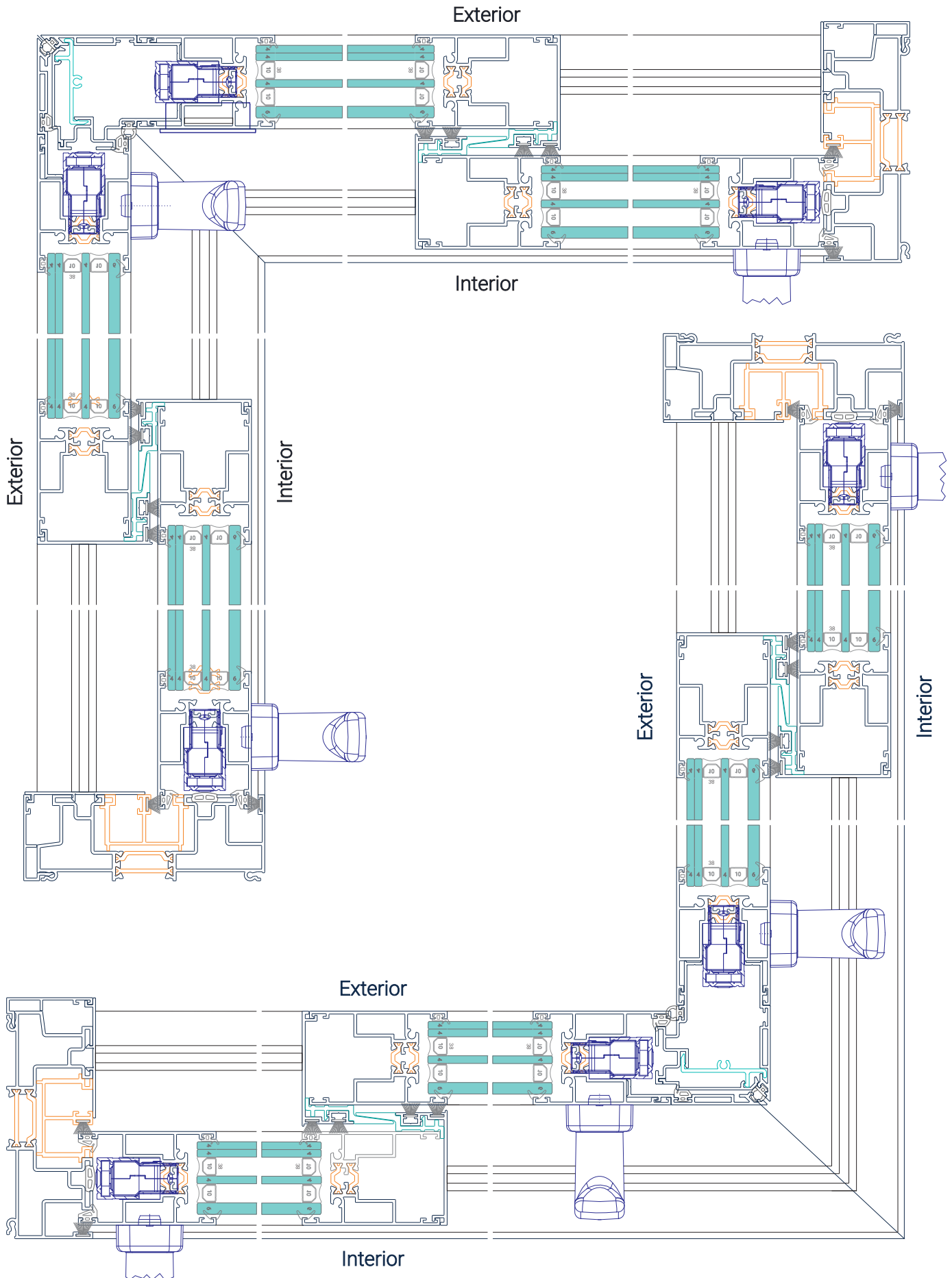

# S.120 - Slim Lift



Abertura de canto (folha do canto no rail interior)

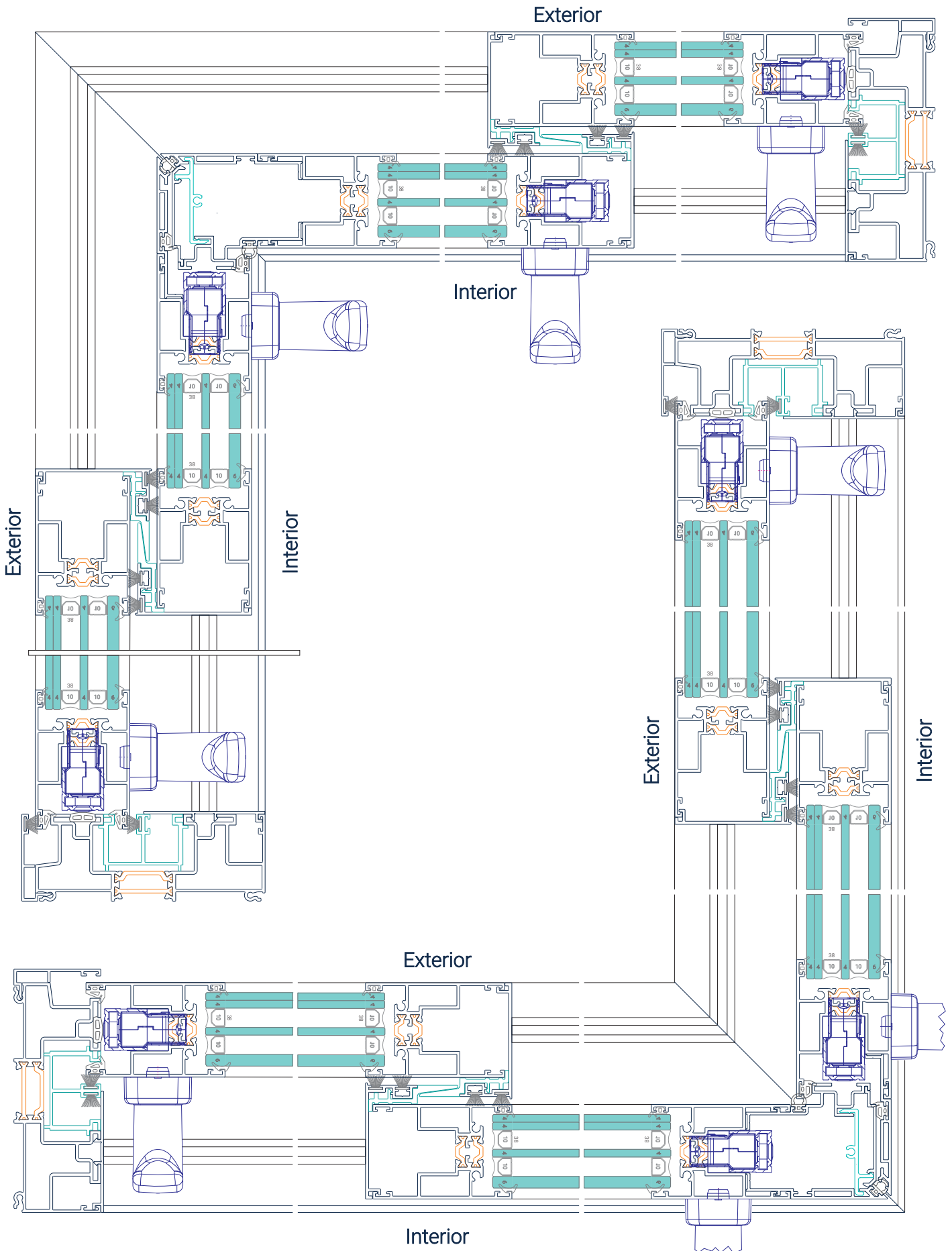

# S.120 - Slim Lift



## Pormenores de Galandage mono-rail

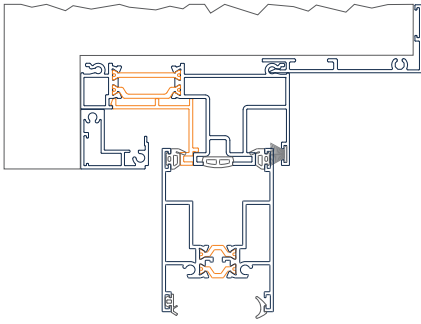

Com Rejingot e Escadouro

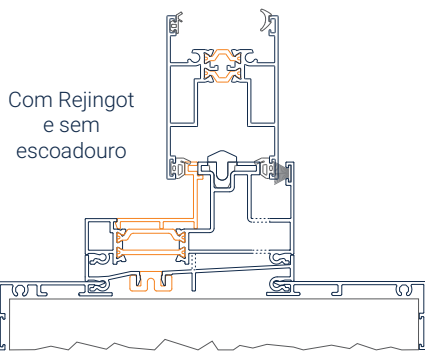
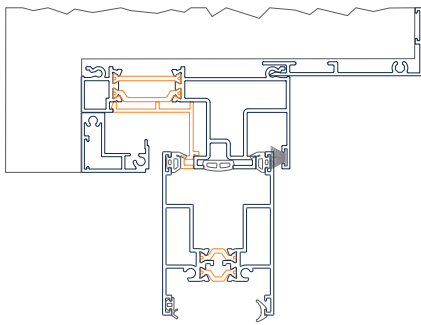
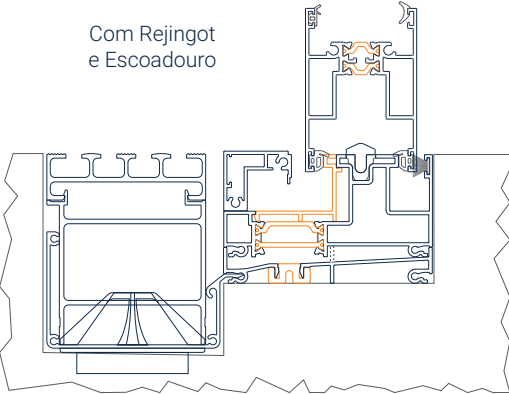

Com Rejingot e sem escoadouro

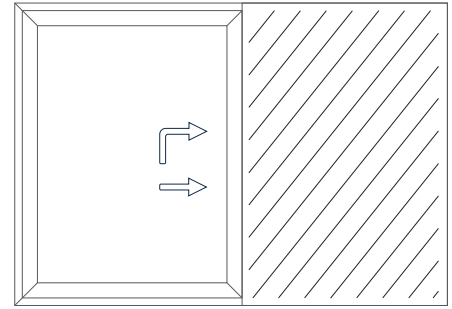

Galandage de 1 folha Elevável ou de Correr

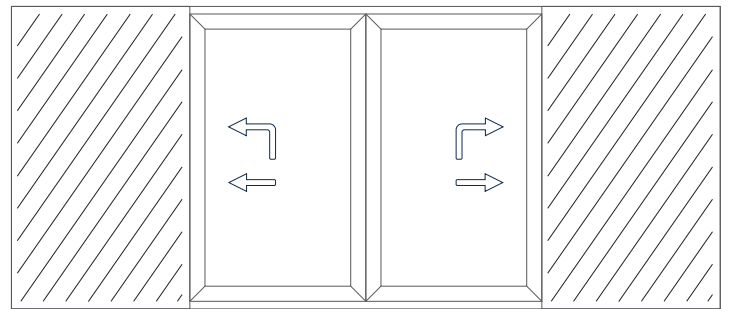
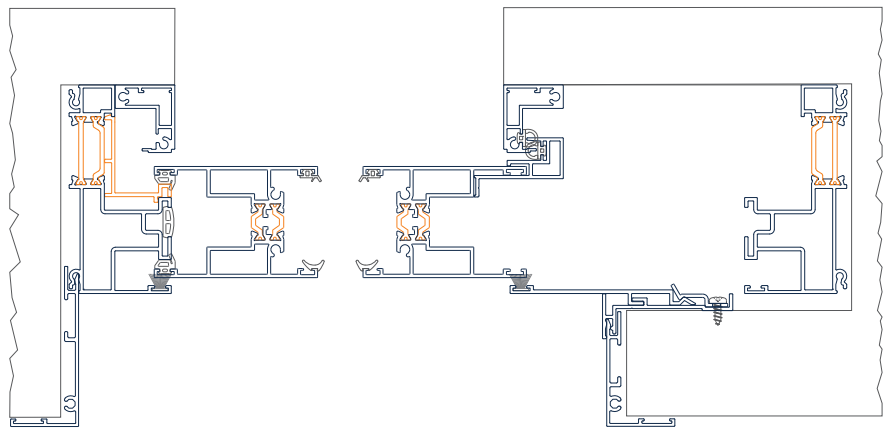

Galandage 2 folhas Eleváveis ou de Correr, 1 para cada lado

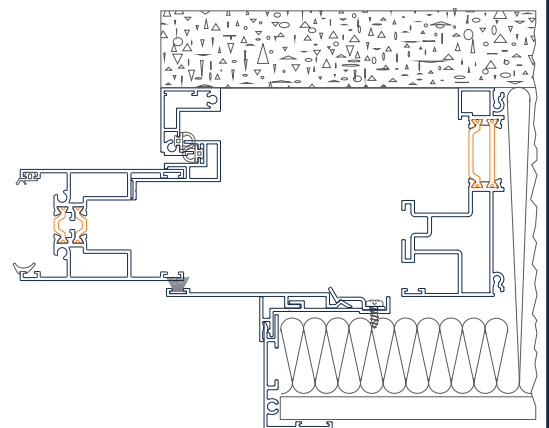
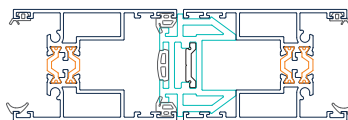
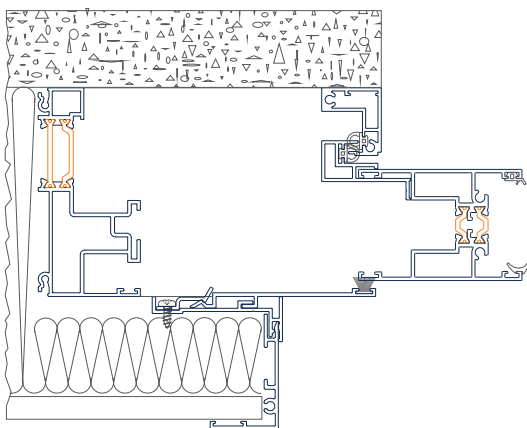

# S.120 - Slim Lift

## Pormenores de Galandage bi-rail

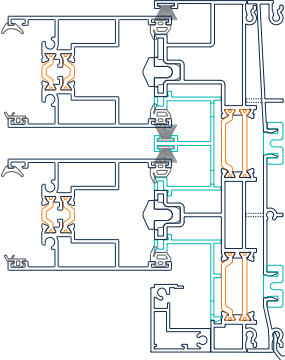
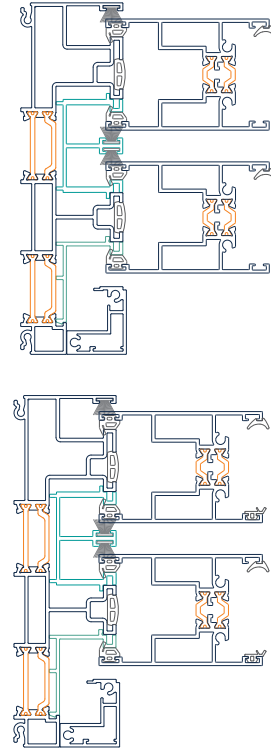

Com Rejingot e Escoadouro

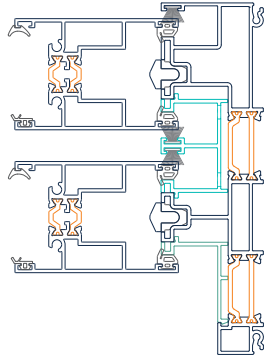
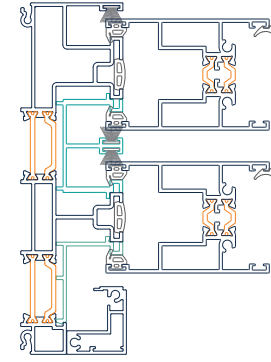

Sem Rejingot

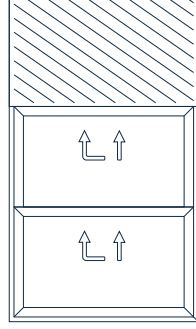
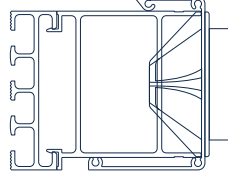

Galandage 2 folhas Eleváveis ou de Correr para o mesmo lado

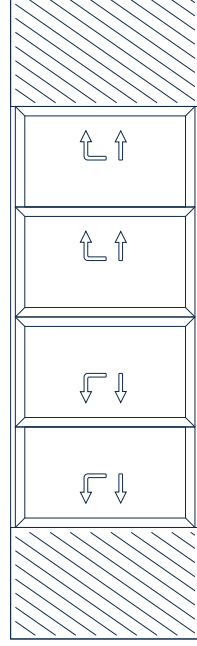
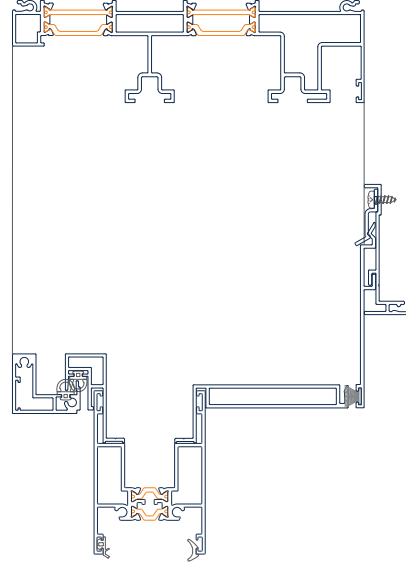
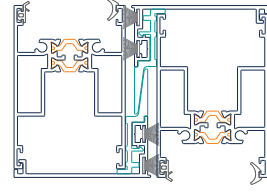
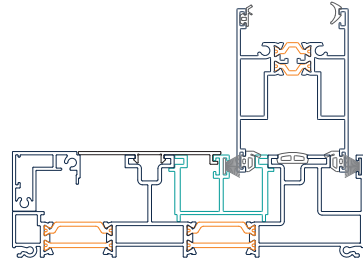

Galandage 4 folhas Eleváveis ou de Correr, 2 para cada lado

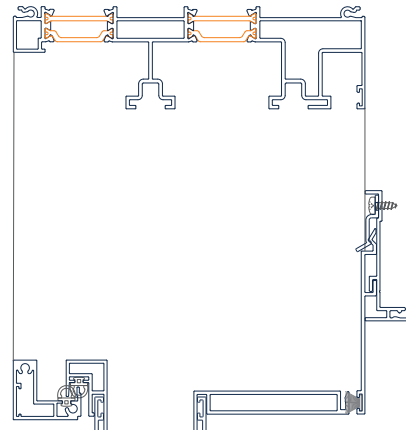
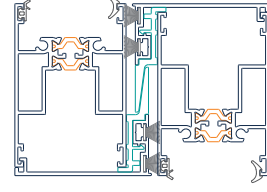
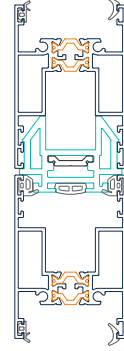
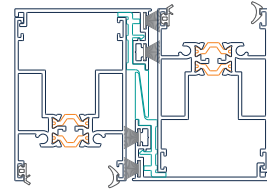

# S.120 - Slim Lift



## Pormenores de Galandage tri-rail

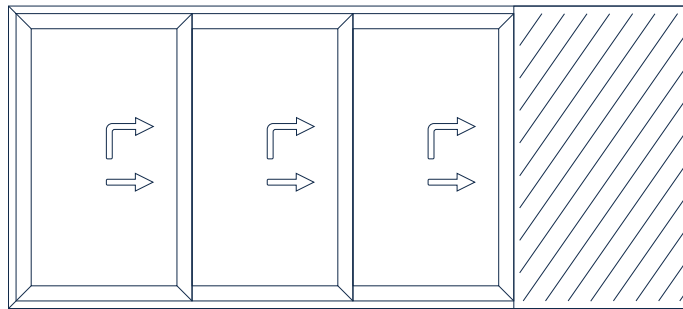

Galandage de 3 folhas Eleváveis ou de Correr para o mesmo lado

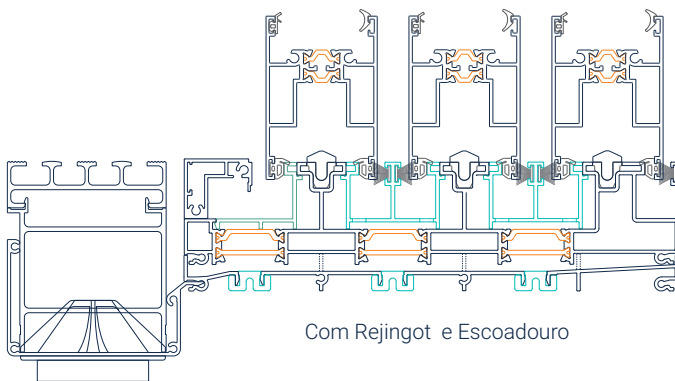
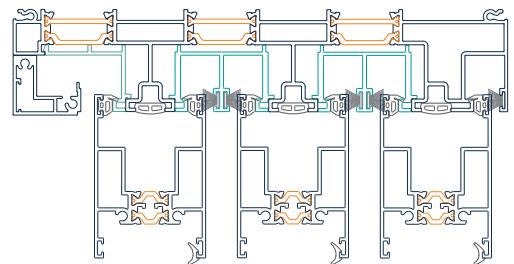
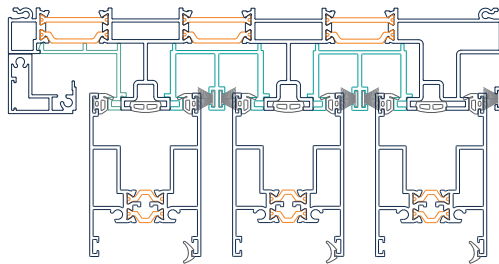

Com Rejingot e Escoadouro

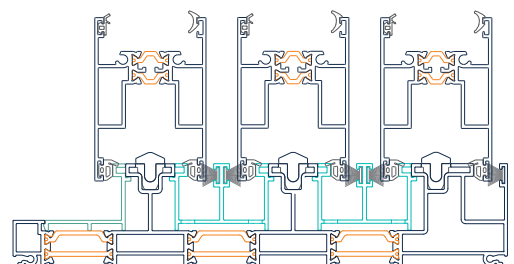

Sem Rejingot

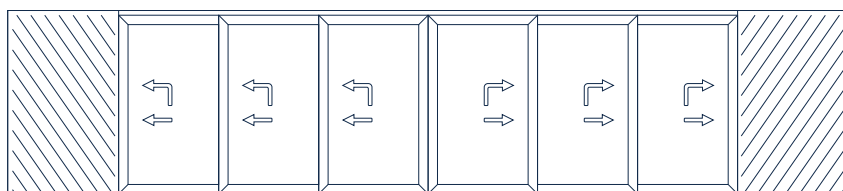
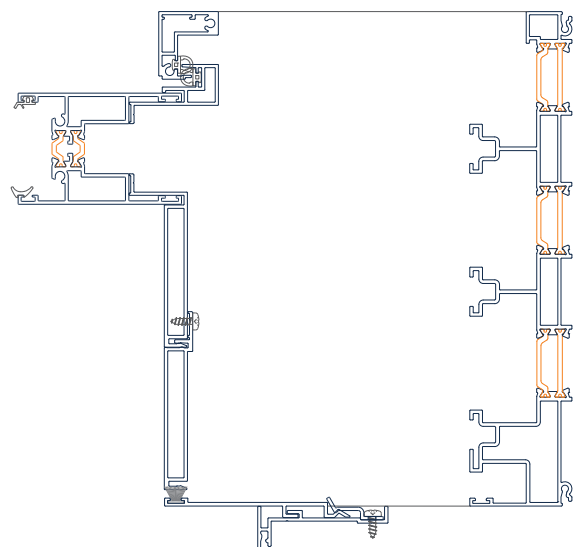
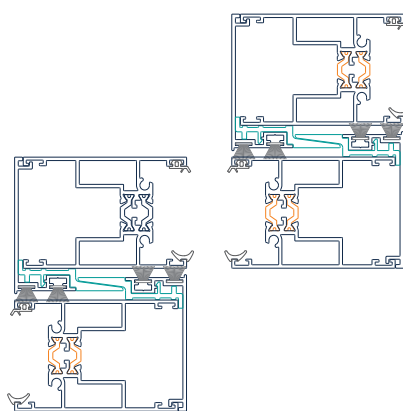
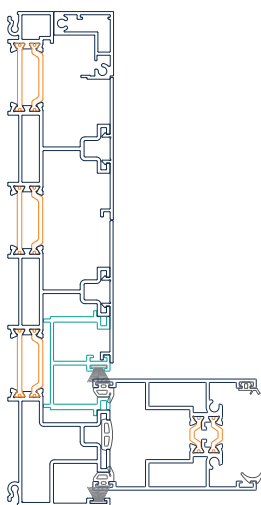

Galandage de 6 folhas Eleváveis ou de Correr, 3 para cada lado

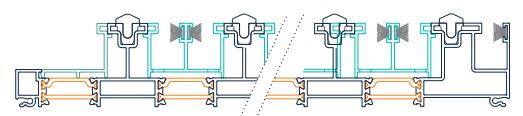

Possibilidade multi-rail para n folhas



# S.120 - Slim Lift



## Esquemas de abertura elevatória "LUCE" (Fapim)

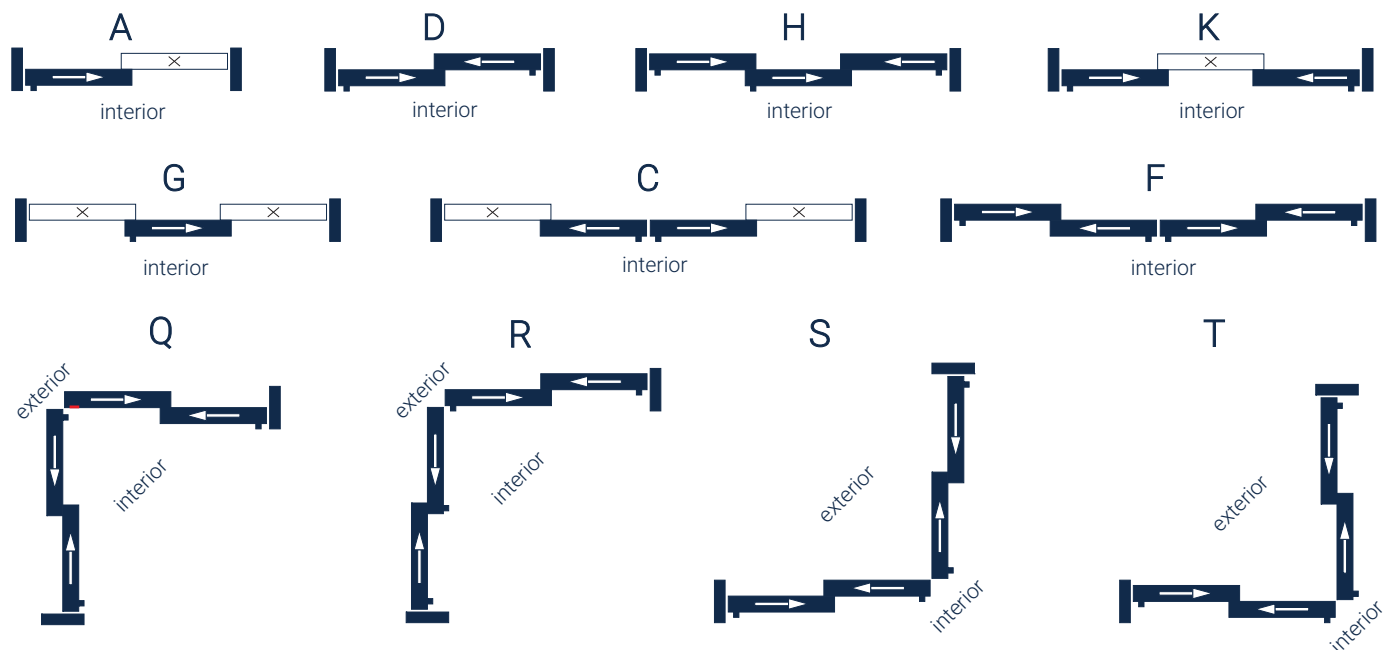

Gastalho por esquema: (para outros esquemas de abertura, consulte departamento técnico)

Acessórios		Limites por folha (mm)/(kg)			Quantidades por esquema											
Designação	Código	L/H	Mínimo	Máximo	A	C	D	F	G	H	K	Q	R	S	T	
Kit carros eleváveis 250Kg	X.63.5223				1	2	2	4	1	3	2	4	4	4	4	
Vareta ligação de carros	X.63.5200	L	730	1650	1	2	2	4	1	3	2	4	4	4	4	
	X.63.5201	L	1651	2050												
	X.63.5202	L	2051	2450												
	X.63.5203	L	2451	3400												
Guia vareta ligação carros	X.63.5222				1	2	2	4	1	3	2	4	4	4	4	
Calço de apoio de folha fixa	X.63.5219				2	4			4		2					
Cremona elevável simples	X.63.5213				1	2	2	4	1	3	2	3	4	4	4	
Cremona elevável c/chave	X.63.5221															
Cremona elev. duplo c/chave	X.63.5215															
Cremona elevável de unha	K.63.2236											1				
Concha externa cremone	X.63.5214		opcional (a)		1	2	2	4	1	3	2	3	4	4	4	
Contra-placa cremone	X.63.5220		opcional (a)													
Auxiliar manobra cremone	X.63.5216		opcional		1	2	2	4	1	3	2	4	4	4	4	
Haste elevatória de janela (cremona a 40mm da base)	X.63.5204	H	810	1200	1	2	2	4	1	3	2	4	4	4	4	
	X.63.5205	H	1175	1800												
Haste elevatória de porta (cremona a 100mm da base)	X.63.5206	H	1775	2150												
	X.63.5207	H	1925	2400												
	X.63.5208	H	2325	2750												
Calço haste elevatória	X.63.5209				4	8	8	16	4	12	8	16	16	16	16	
Ponto fecho simples	X.63.5210				2	4	4	8	2	6	4	8	8	8	8	
Ponto fecho para ventilação	X.63.5211		opcional													
Ponto fecho suplementar	X.63.5210		opcional (b)		1	2	2	4	1	3	2	4	4	4	4	
Batente limitador abertura	X.63.5212				1	2	1	2	2	2	2	2	2	2	2	
Kit carros suplementares	X.63.5224	P	251kg	350kg	1	2	2	4	1	3	2	4	4	4	4	

(a) - Incompatível com cremone duplo X.63.5215

(b) - Ponto de fecho suplementar para hastes de porta X.63.5206/07/08

# S.120 - Slim Lift



## Esquemas de abertura elevatória "Design Lockig" (Roto Frank)

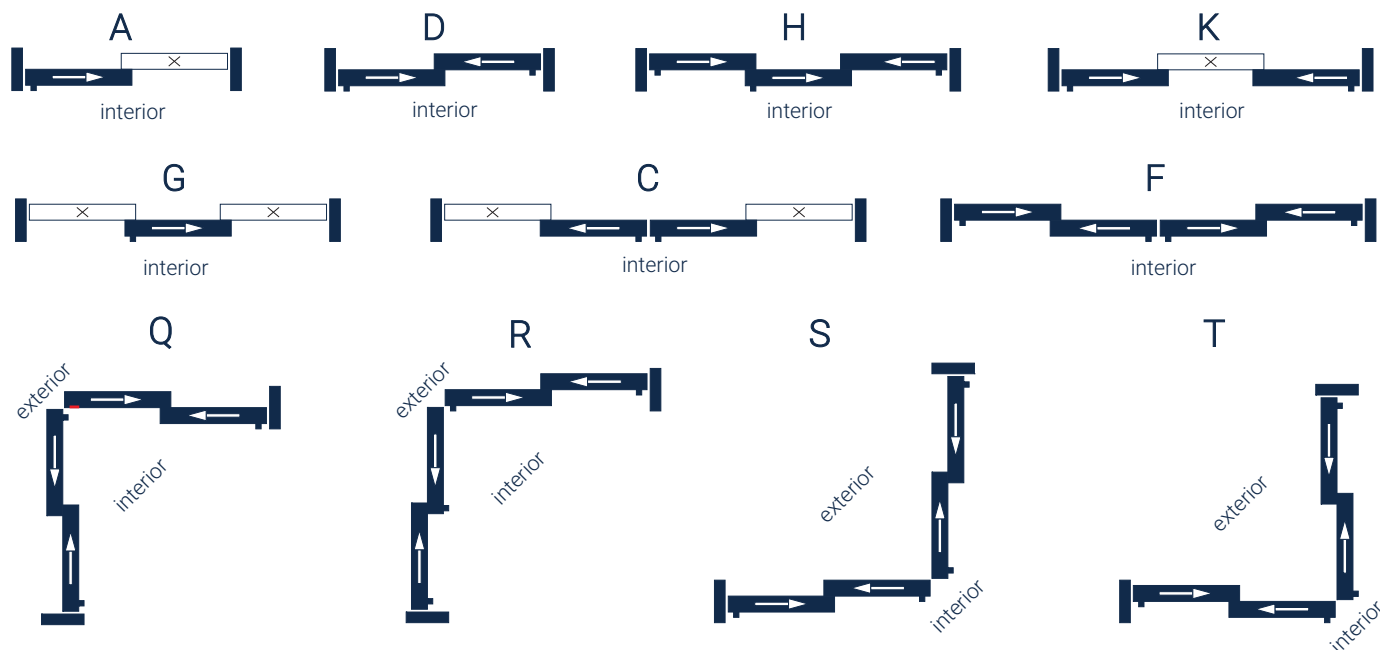

Gastalho por esquema: (para outros esquemas de abertura, consulte departamento técnico)

Acessórios		Limites por folha (mm)/(kg)			Quantidades por esquema											
Designação	Código	L/H	Mínimo	Máximo	A	C	D	F	G	H	K	Q	R	S	T	
Kit carros eleváveis 200Kg	X.63.7238				1	2	2	4	1	3	2	4	4	4	4	
Apoio descanso de carros	X.63.7258				1	2	2	4	1	3	2	4	4	4	4	
Vareta ligação de carros	X.63.5243	L	730	1400	1	2	2	4	1	3	2	4	4	4	4	
	X.63.5244	L	1401	1700												
	X.63.5245	L	1701	2000												
	X.63.5246	L	2001	2300												
	X.63.5247	L	2301	3000												
Calço de apoio de folha fixa	X.63.5219				2	4			4		2					
Cremona elevável simples	X.63.7255				1	2	2	4	1	3	2	3	4	4	4	
Cremona elevável c/chave	X.63.7260															
Cremona elev. duplo c/chave	X.63.7262															
Quadra 10mm p/ cremone	X.63.7257				1	2	2	4	1	3	2	3	4	4	4	
Parafuso para cremone	X.63.7259				1	2	2	4	1	3	2	3	4	4	4	
Cremona elevável de unha	K.63.2236											1				
Concha externa cremone	X.63.7256		opcional (a)		1	2	2	4	1	3	2	3	4	4	4	
Haste "Design Locking" Basic (Folhas até 300Kg)	X.63.7248	H	1800	2200	1	2	2	4	1	3	2	4	4	4	4	
	X.63.7249	H	2200	2600												
	X.63.7250	H	2600	3100												
Haste "Design Locking" Soft Lift (Folhas acima de 300Kg)	X.63.7251	H	1800	2200	1	2	2	4	1	3	2	4	4	4	4	
	X.63.7252	H	2200	2600												
	X.63.7253	H	2600	3100												
Calço haste elevatória	X.63.7241				1	2	2	4	1	3	2	4	4	4	4	
Calço carro/ haste	X.63.7240				1	2	2	4	1	3	2	4	4	4	4	
Ponto fecho simples	X.33.0155				2	4	4	8	2	6	4	8	8	8	8	
Ponto fecho para ventilação	X.63.7254				opcional											
Batente limitador abertura	X.63.7242				1	2	1	2	2	2	2	2	2	2	2	
Kit carros suplementares	X.63.7239	P	201kg	400kg	1	2	2	4	1	3	2	4	4	4	4	

(a) - Incompatível com cremone duplo X.63.7262

# S.120 - Slim Lift

Montagen da soleira com rejingot e escoador

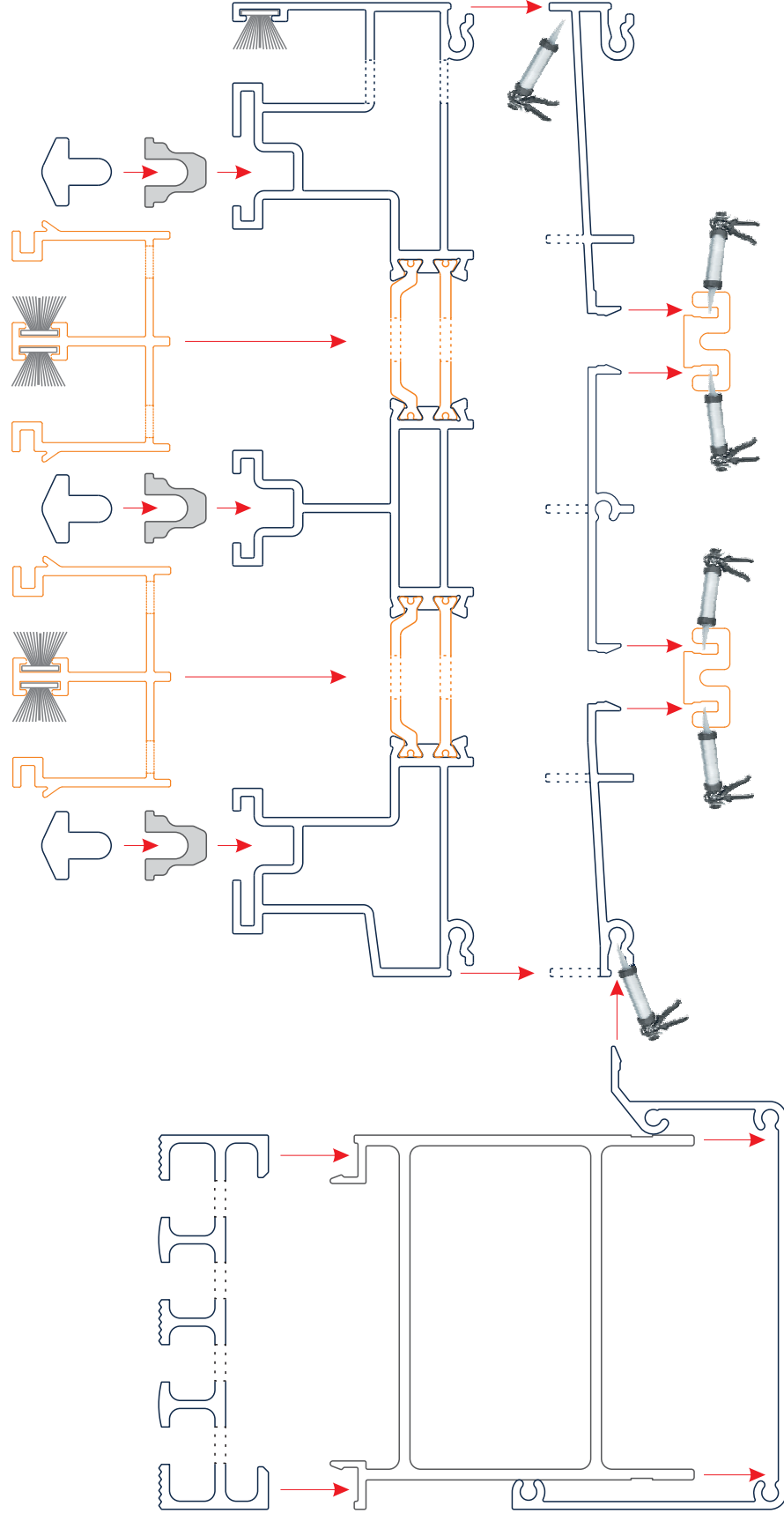

# S.120 - Slim Lift



## Operações de Cunho

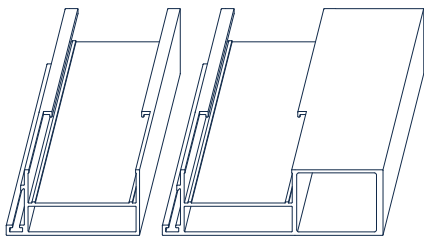
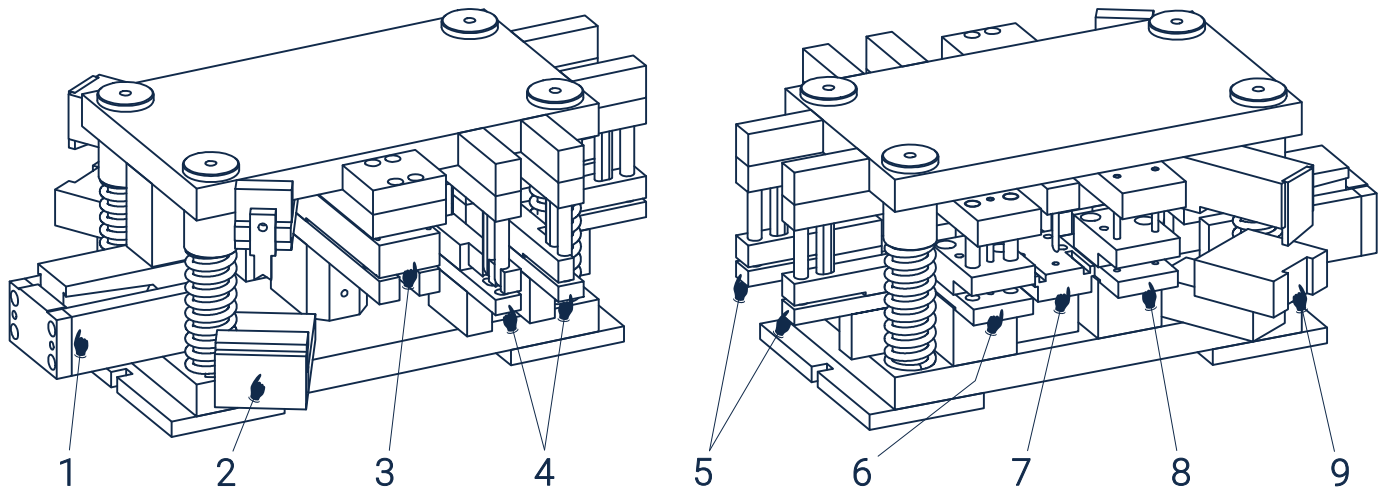

1) - Entalhe dos centrais  
S.120.300 e S.120.310

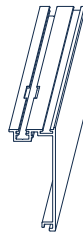

2) - Escariador cabeça do parafuso  
de aperto do S.120.201

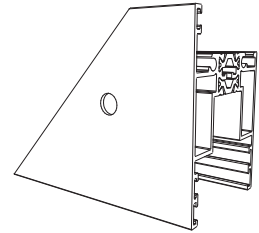

3) - Furos do batente limit. abertura

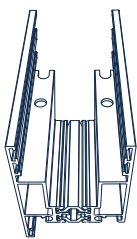

4) - Esquadros do aro móvel

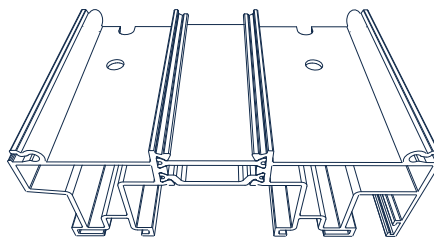

5) - Esquadros aro fixo

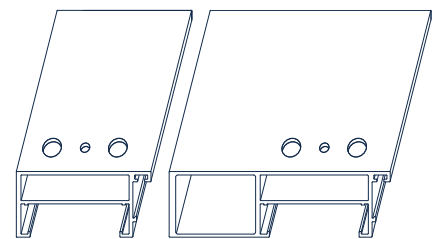

6) - Furos exteriores aperto  
S.120.300 e S.120.310

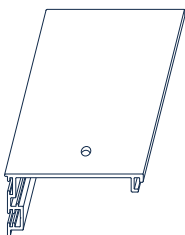

7) - Furo do guia  
S.120.201

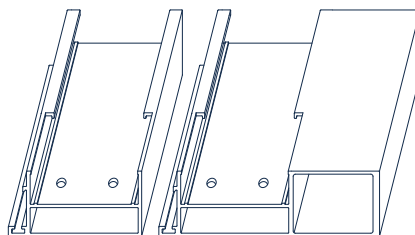

8) - Furos interiores aperto  
S.120.300 e S.120.310

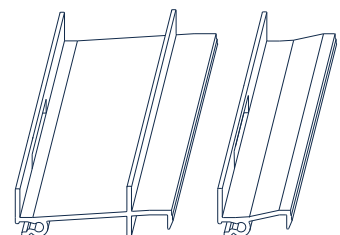

9) - Goteira do rejingot  
S.120.431 e S.120.435

# S.120 - Slim Lift



S.120.100 Alumínio AC.00-Nat / AC.05-Prt



S.120.201 Alumínio à Cor



S.120.320 Alumínio à Cor



S.120.102 Alumínio à Cor

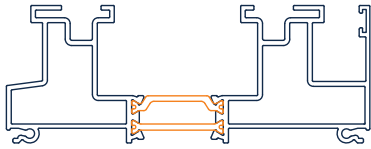

S.120.210 Alumínio à Cor

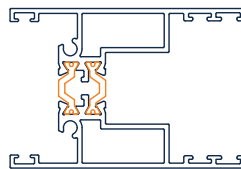

S.120.337 Alumínio à Cor



S.120.103 Alumínio à Cor

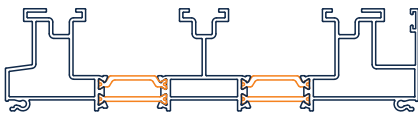

S.120.220 Alumínio à Cor

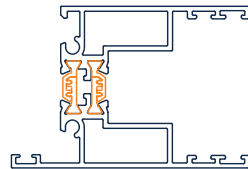

S.120.411 Alumínio à Cor

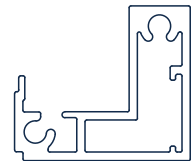

S.120.111 Alumínio à Cor

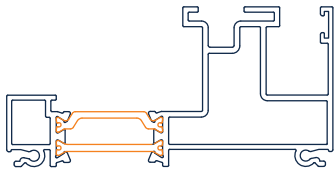

S.120.230 Alumínio à Cor

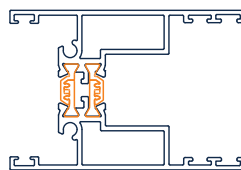

S.120.412 Alumínio à Cor



S.120.112 Alumínio à Cor

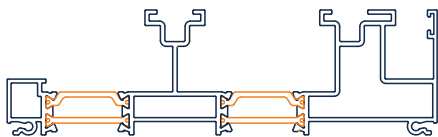

S.120.237 Alumínio à Cor



S.120.413 Alumínio à Cor



S.120.121 Alumínio à Cor

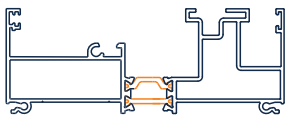

S.120.241 Alumínio à Cor



S.120.414 Alumínio à Cor

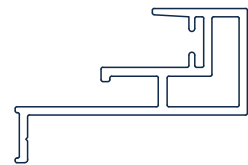

S.120.122 Alumínio à Cor

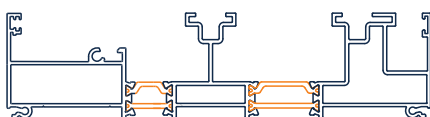

S.120.300 Alumínio à Cor

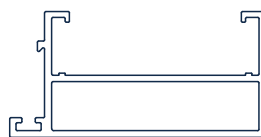

S.120.415 Alumínio à Cor



S.120.200 Alumínio à Cor

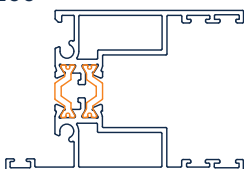

S.120.310 Alumínio à Cor

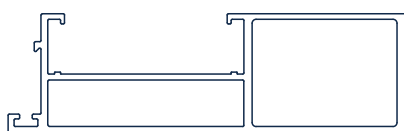

S.120.416 Alumínio à Cor



# S.120 - Slim Lift



S.120.421 Alumínio à Cor

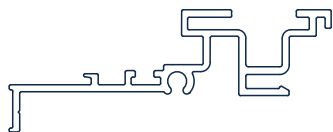

S.120.501 Alumínio à Cor



S.120.911 Poliamida c/ drenagem

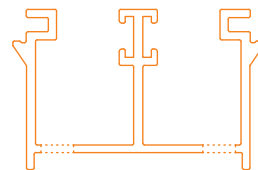

S.120.422 Alumínio à Cor



S.120.502 Alumínio à Cor



S.120.912 Poliamida



S.120.423 Alumínio à Cor



S.120.503 Alumínio à Cor



S.120.920 PVC



S.120.430 Alumínio AC.00-Nat

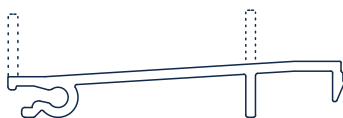

S.120.504 Alumínio à Cor



S.120.921 PVC



S.120.431 Alumínio à Cor

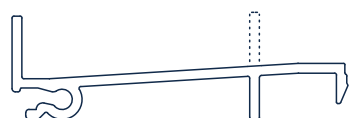

Y.0020 Alumínio AC.00-Nat / AC.05-Prt



S.120.922 PVC

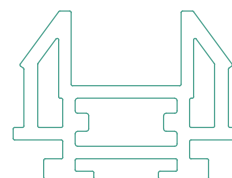

S.120.432 Alumínio AC.00-Nat

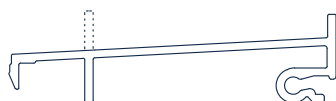

Y.0301 Alumínio AC.00-Nat

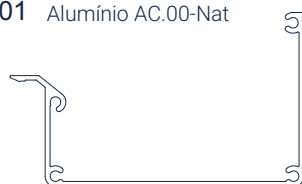

S.120.923 PVC

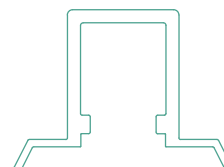

S.120.433 Alumínio AC.00-Nat

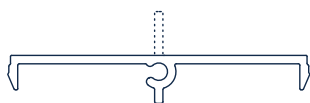

Y.0302 Alumínio AC.00-Nat

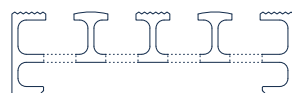

S.120.930 PVC



S.120.435 Alumínio à Cor



S.120.910 Poliamida

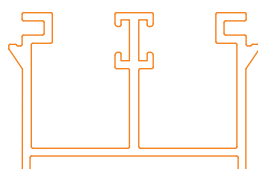

S.120.940 PVC

